

IEC 61400-25

Seminar Boulder (Colorado)

2003-11-17

Schwarz Consulting Company, SCC
Dipl.-Ing. Karlheinz Schwarz
Im Eichbaeumle 108
76139 Karlsruhe / Germany

Tel **+49-721-684844**
Fax **+49-721-679387**
Email **schwarz@scc-online.de**
URL **www.scc-online.de**



animated slides

Short curriculum vitae of Karlheinz Schwarz

Dipl.-Ing. **Karlheinz Schwarz** is president of SCC (Schwarz Consulting Company), Karlsruhe (Germany) specializing in distributed automation systems.

He is involved in many standardization activities within IEC (TC 57, TC 65, TC 88), ISO (TC 184), CENELEC (TC 65 CX), IEEE (SCC 36 "UCA", 802), and DIN since 1985.

He is engaged in representing main industry branches in the global standardization and providing consulting services to users and vendors.

Specifically, his contributions to the publication of many standards are considered to be outstanding.

Mr. Schwarz is a well-known authority on the application of mainstream information and communication technologies.

Schwarz Consulting Company (SCC)

Supplier Information, Capabilities, and Experience Profile

The primary business objective of SCC is to provide consulting services to all kind of enterprises for feasibility studies, design, specifying and editing international standards, training, marketing, information dissemination, procurement of distributed systems and open communications for the various aspects of distributed automation systems.

To keep abreast of the latest technical development, SCC is actively involved in workshops, seminars, task forces, and committees of various professional organizations such as ISO, IEC, IEEE, CEN, and CENELEC.

Major Customers of SCC

Users: Bayernwerk, Badenwerk, EON, EVS, HEW, Mercedes Benz, RWE, VEW

Vendors: AEG, ABB, Alstom, Bosch, E+H, IDS, Eberle, Kloeckner & Möller, Pepperl & Fuchs, Phoenix Contact, PSI, Repas AEG, SAT, Siemens

Institutes: DIN, EPRI (USA), FGH Mannheim, FH Offenburg, PNO, VDMA, ZVEI

Download all slides of the seminar

www.scc-online.de/std/61400

List of Contents

What to exchange?

Wind power plant **information** and
information exchange

1/2 How to exchange?

Mappings to protocol stacks

1/2 How to exchange?

Migration

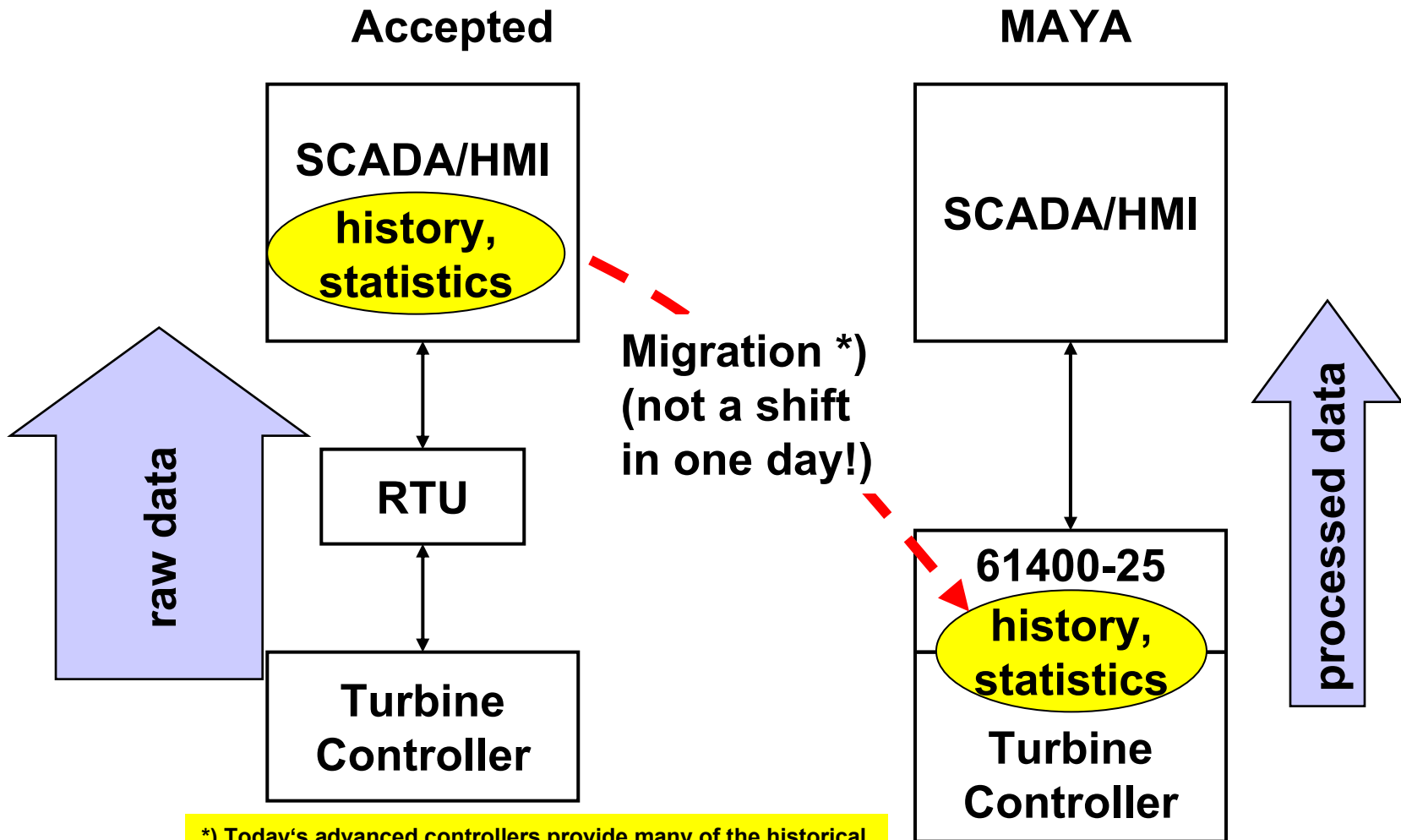

*) Today's advanced controllers provide many of the historical and statistical information. In this regard the standard IEC 61400-25 follows the market - not vice versa.

MAYA – Most advanced yet accepted

General implementation objective

Simple SOLUTION for simple requirements

Simple SUBSET of IEC 61400-25 for simple requirements

Wind power plant information

Connection is not communication



Need to define
some meaningful
things

What to define and exchange?

Data of wind power plant components

- Wind turbine
- Wind generator
- Nacelle
- Rotor
- Converter
- Yaw
- ...

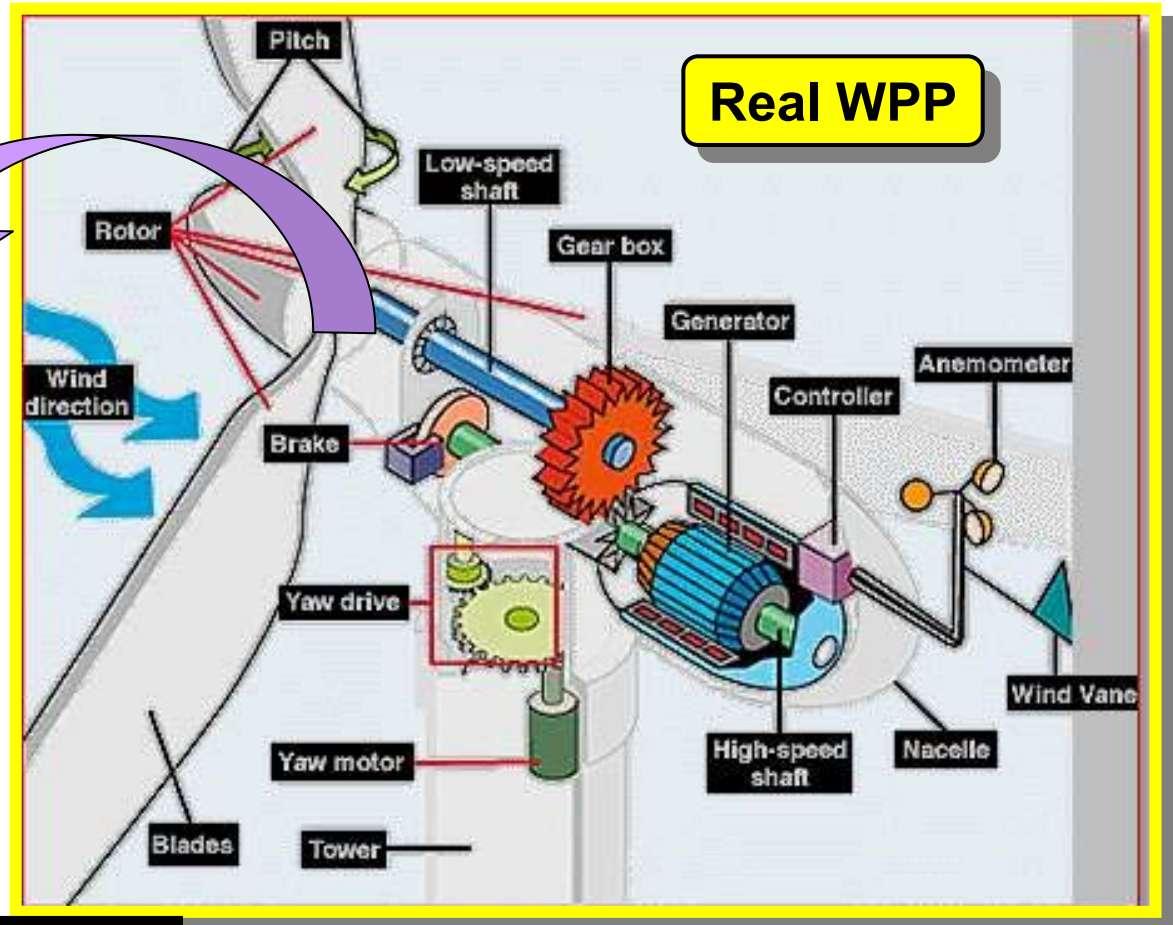

Information Models

Drawing developed by the U.S. Department of Energy - Wind Energy Program

What to define and exchange?

Information Model

Generator: Measurands

Generator speed
Generator active power
Generator reactive power
Temperature measurements
Current measurements
Voltage measurements
...

Generator: Status information

Operation mode (Run, ...)
Generator cooling system
...

Real Generator

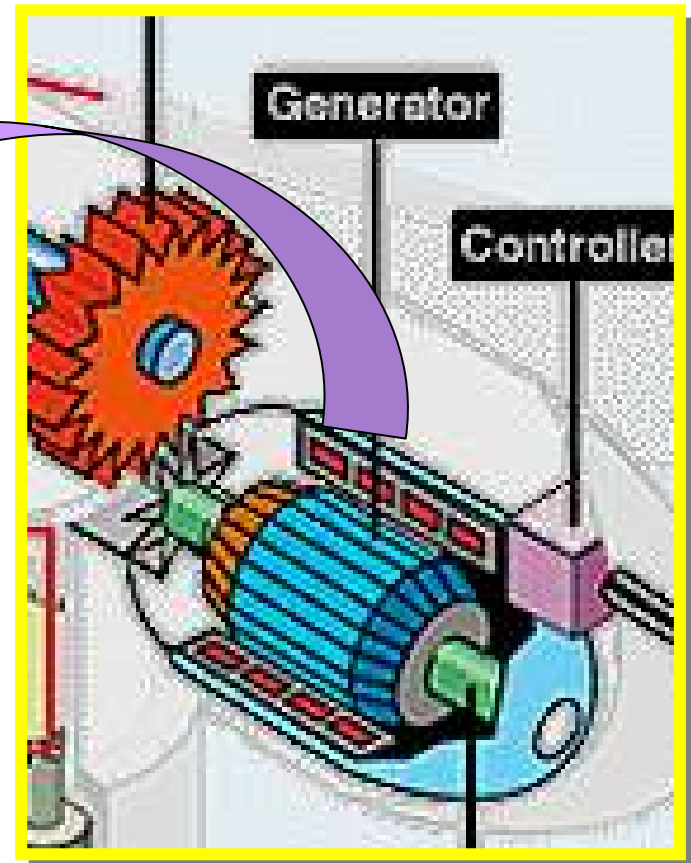

What is an Information model?

**An Information MODEL
in IEC 61400-25**

**is a list of „signals“
arranged according to the
components of real power plants.**

What is an Information model?

... a list of
named „signals“ ...

What to put, e.g., into the list?

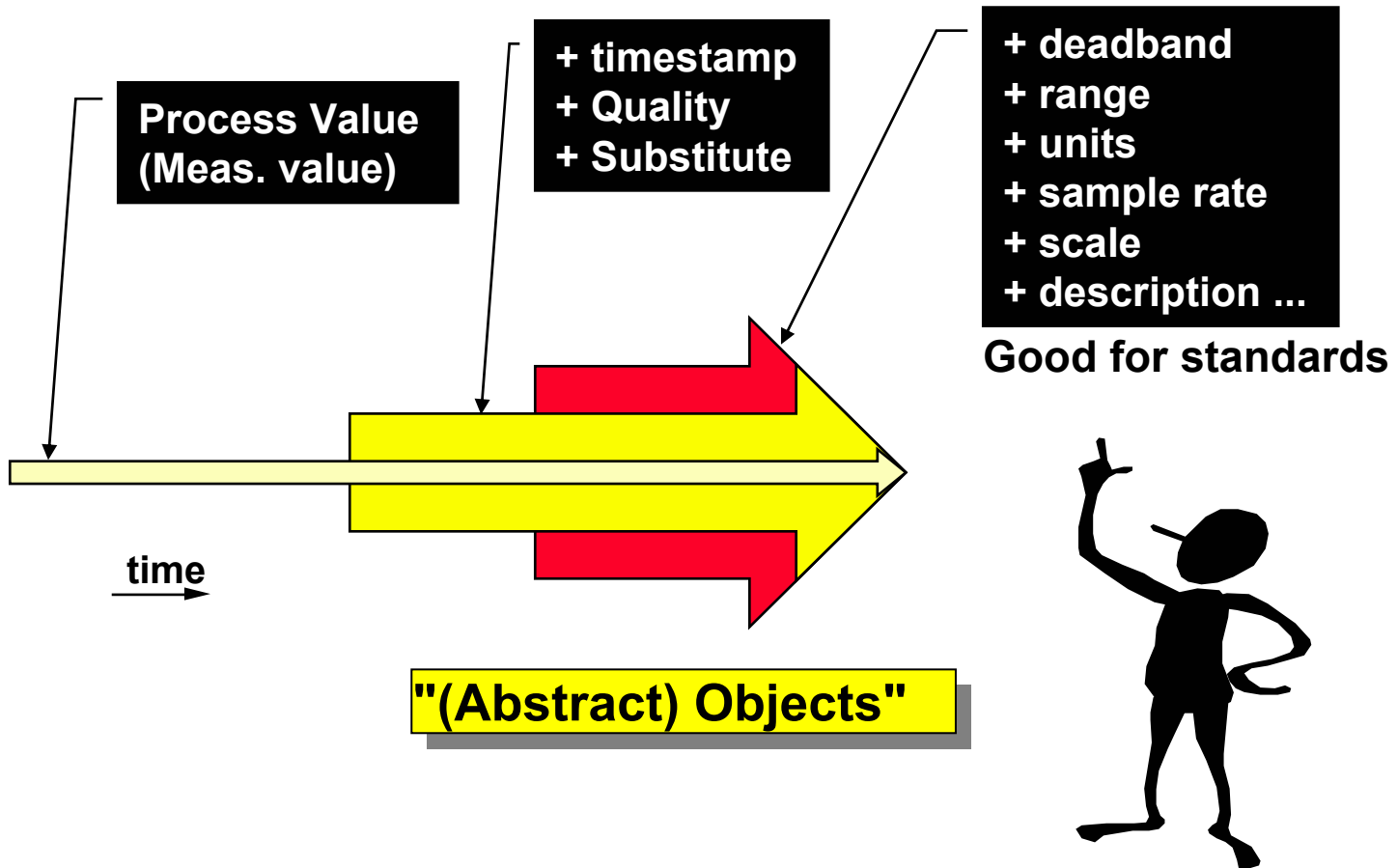

Lists, lists, lists, ...

**... communication
systems rely on
point lists – so does
IEC 61400-25**

Example: Proprietary „Power Monitor“ Points List for DNP3

130 Pages !

30 4 = 16-Bit Analog Input without Flag (Data Class)

(Range)

(Multi.Units)

(Data Type)

Obj	Var	Index	Line	Description	Range	Units	Type
30	4	1615	188	Phase B Current 119 th Harmonic Phase	+180 degree / -180 degree	0.01 degree	F6
30	4	1616	188	Phase B Current 120 th Harmonic Phase	+180 degree / -180 degree	0.01 degree	F6
30	4	1617	188	Phase B Current 121 st Harmonic Phase	+180 degree / -180 degree	0.01 degree	F6
30	4	1618	188	Phase B Current 122 nd Harmonic Phase	+180 degree / -180 degree	0.01 degree	F6
30	4	1619	188	Phase B Current 123 rd Harmonic Phase	+180 degree / -180 degree	0.01 degree	F6
30	4	1620	188	Phase B Current 124 th Harmonic Phase	+180 degree / -180 degree	0.01 degree	F6
30	4	1621	188	Phase B Current 125 th Harmonic Phase	+180 degree / -180 degree	0.01 degree	F6
30	4	1622	188	Phase B Current 126 th Harmonic Phase	+180 degree / -180 degree	0.01 degree	F6
30	4	1623	188	Phase B Current 127 th Harmonic Phase	+180 degree / -180 degree	0.01 degree	F6
30	4	1624	189	Phase B Current 128 th Harmonic Phase	+180 degree / -180 degree	0.01 degree	F6
30	4	1625	189	Phase B Current 129 th Harmonic Phase	+180 degree / -180 degree	0.01 degree	F6
30	4	1626	189	Phase B Current 130 th Harmonic Phase	+180 degree / -180 degree	0.01 degree	F6
30	4	1627	189	Phase C Current 3 rd Harmonic Phase	+180 degree / -180 degree	0.01 degree	F6

Index 1615 = Phase B Current 119th Harmonic Phase (Meaning)

Replace Index by Name, and ...

Basic Type FLOAT32

(Data Type)

AnalogueValue

**30 4 = 16-Bit Analog Input
without Flag (Data Class)**

(Range)

(Multi.Units)

Multiplier - Units

Obj	Var	Index	Line	Description	Range	Units	Type
30	4	1615	188	Phase B Current 119 th Harmonic Phase	+180 degree / -180 degree	0.01 degree	F6
30	4	1616	188	Phase B Current 120 th Harmonic Phase	+180 degree / -180 degree	0.01 degree	F6
30	4	1617	188	Phase B Current 121 st Harmonic Phase	+180 degree / -180 degree	0.01 degree	F6
30	4	1618	188	Phase B Current 122 nd Harmonic Phase	+180 degree / -180 degree	0.01 degree	F6
30	4	1619	188			0.01 degree	F6
30	4	1620	188			0.01 degree	F6
30	4	1621	188			0.01 degree	F6
30	4	1622	188		+180 degree / -180 degree	0.01 degree	F6
30	4	1623	188		+180 degree / -180 degree	0.01 degree	F6
30	4	1624	189		+180 degree / -180 degree	0.01 degree	F6
30	4	1625	189		+180 degree / -180 degree	0.01 degree	F6
30	4	1626	189		+180 degree / -180 degree	0.01 degree	F6
30	4	1627	189	Phase C Current 3 rd Harmonic Phase	+180 degree / -180 degree	0.01 degree	F6

MHAI.HA.PhsBHar119.ang

**Index 1615 = Phase B
Current 119th
Harmonic Phase
(Meaning)**

Replace Index by Name, and ...

... It's as simple as that

to define an

information model!

No magic at all.

Result is IEC 61400-25 ...

**... ONE standardized
(and extensible) „List“
comprising all relevant
information accessible in WPPs**

IEC 61400-25 model summary

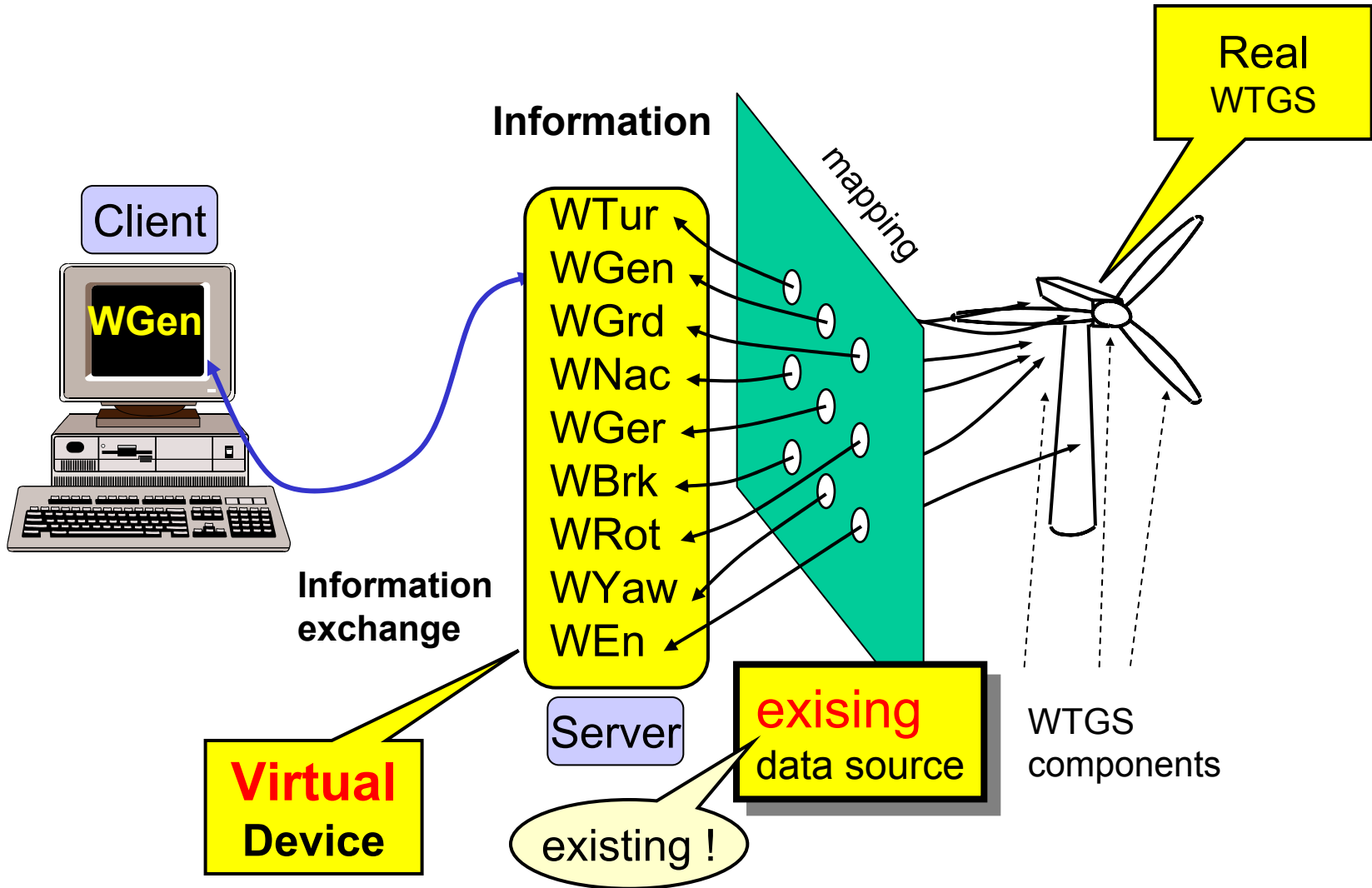

Wind turbine information models

WTUR	Wind turbine general information	M
WROT	Wind turbine rotor information	M
WTRM	Wind turbine transmission information	O
WGEN	Wind turbine generator information	M
WCNV	Wind turbine converter information	O
WGDC	Wind turbine grid connection information	M
WNAC	Wind turbine nacelle information	O
WYAW	Wind turbine yawing information	M
WTOW	Wind turbine tower information	O
WMET	Wind power plant meteorological information	M
WALM	Wind turbine alarm information	M
WSLG	Wind turbine state log information	O
WALG	Wind turbine analogue log information	O
WREP	Wind turbine report information	O

Logical Node (just a box)

mandatory / optional

Wind turbine general info (WTUR)

WTUR class			
Attribute Name	Attr. Type	Explanation	T M/C/O
LNNName		Shall be inherited from Logical-Node Class (see IEC 61850-7-2)	
Data			
General information			
		LN shall inherit all Mandatory Data from Wind Power Plant Common Logical Node Class	M
TurAvlTm	TMS	Turbine availability time	M
TurOpTm	TMS	Turbine operation time	O
TurStrCt	CTE	Number of turbine starts	O
TurStpCt	CTE	Number of turbine stops	O
State information			
TurSt	STV	Windturbine status	M
Analogue information			
TotEgyAt	AMV	Total active energy generation	M
TotEgyRt	AMV	Total reactive energy generation	O
TotPwrAt	AMV	Total active power production	M
TotPwrRt	AMV	Total reactive power production	O
Control information			
SetTurOp	CMD	Wind turbine operation mode	M
Setpoint information			
DmdPwrAt	SPV	Turbine active power production setpoint	O
DmdPwrRt	SPV	Turbine reactive power production setpoint	O
DmdPwf	SPV	Turbine power factor setpoint	O

Meaning = Total active energy generation

Type = AMV (Analogue Measured Value)

Name = TotEgyAt



Analogue measured value (AMV) (1)

AMV class					
Attribute Name	Attribute Type	FC	TrgOp	Explanation and Value / Range	M/O
DataName	Inherited from Data Class (see IEC 61850-7-2)				
DataAttribute					
instantaneous analogue information					
instMag	AnalogueValue	MX		Instantaneous value	O
analogue information selector					
selAnType	CODED ENUM			deadband, avarage, rms to be stored in the arrays below	M
deadbanded analogue information					
mag	AnalogueValue	MX	dchg	Deadbanded value	selAnType = deadband
avaraged analogue information					
avgVal	AnalogueValue	MX	dupd	Average value	selAnType = avarage
rms analogue information					
rmsVal	AnalogueValue	MX	dchg	Root-mean-square value (effective)	selAnType = rms
common analogue information					
t	TimeStamp	MX		Time value	M
q	Quality	MX	qchg	Quality	M
range	ENUMERATED	MX	dchg	normal high low high-high low-low ...	O
anId	INT32U	MX		local identifier of mag, avgVal, or rmsVal depending on selAnType	O
Data					
chHis	CHA				O
DataAttribute					

Analogue measured value (AMV) (2)

AMV class (continued)					
Attribute Name	Attribute Type	FC	TrgOp	Explanation and Value / Range	M/O
configuration, description and extension information					
units	Unit	CF		see IEC 61850-7-3 for details	O
db	INT32U	CF		0 ... 100 000	selAnType = deadband
zeroDb	INT32U	CF		0 ... 100 000	selAnType = deadband
avgPer	CODED ENUM 1	CF	dchg	Averaging period 1 (the averaging period shall start at 00:00 h of a day (or a multiple of the value) 10min 1min 30sec 3sec	selAnType = average
rmsTmms	INT32U	CF		Rms calculation period (in milliseconds)	selAnType = rms
sVC	ScaledValueConfig	CF			AC_SCAV
rangeC	RangeConfig	CF			GC_CON
smpRate	INT32U	CF			O
d	VISIBLE STRING255	DC		Text	O
dU	UNICODE STRING255	DC			O
cdcNs	VISIBLE STRING255	EX			AC_DLNDA_M
cdcName	VISIBLE STRING255	EX			AC_DLNDA_M
dataNs	VISIBLE STRING255	EX			AC_DLN_M
1 Editor's note: This attribute avgPer may be better of type INT32U; value in ms; (constraint: the period of 24:00 h shall be divisable by the value of avgPer without remainder).					

Analogue measured value (AMV) (3)

only mandatory attributes

AMV class			
Attribute Name	Attribute Type	Explanation and Value / Range	M/O
DataAttribute			
selAnType	CODED ENUM	deadband, average, rms to be stored in the arrays below	M
mag	AnalogueValue	Deadbanded value	selAnType = deadband
t	TimeStamp	Time value	M
q	Quality	Quality	M

Read "WTUR.TotEgyAt" returns <mag> <t> <q>

unsolicited report: <"WTUR.TotEgyAt"> <mag> <t> <q>

or <1> <mag> <t> <q>

"report index" of data set

Characteristic (CHA)

CHA class (Characteristics of an analogue value)					
Attribute Name	Attribute Type	FC	TrgOp	Explanation and Value / Range	M/O
<i>characteristics information</i>					
maxVal	AnalogueValue	MX		Maximum value	M
minVal	AnalogueValue	MX		Minimum value of data	O
totAvgVal	AnalogueValue	MX		Total average value of data	M
sdvVal	AnalogueValue	MX		Standard deviation of data	O
opRs	INT16U	MX		Operator identifier of last reset	O
tRs	TimeStamp	MX	dchg	Timestamp at last reset	O
q	Quality	MX	qchg	Quality	M
<i>historical information</i>					
hlyMax	AnalogueValue [25]	MX		hourly max value	O
dlyMax	AnalogueValue [32]	MX		daily max value	O
mlyMax	AnalogueValue [13]	MX		monthly max value	O
ylyMax	AnalogueValue [21]	MX		yearly max value	O
hlyMin	AnalogueValue [25]	MX		hourly min value	O
dlyMin	AnalogueValue [32]	MX		daily min value	O
mlyMin	AnalogueValue [13]	MX		monthly min value	O
ylyMin	AnalogueValue [21]	MX		yearly min value	O
hlyAvg	AnalogueValue [25]	MX		hourly average	O
dlyAvg	AnalogueValue [32]	MX		daily average	O
...					

Minimum list of all mandatory

**With the conversion of the tables to XML file
→ we can easily filter all “M” (XML transformation) and
generate “M” tables.**

**Mapping to variables and registers is simple (see mapping
to IEC 60870-5-10x and DNP3).**

**Retrieval of information model from XML file (SCL) or
directly from device (with mapping of „name“ to index or
register number) is supported.**

Further Information Models ...

WPP models under discussion:

- Control of whole park (frequency control, ...)
- Condition monitoring

Models for substation devices:

- inherited from IEC 61850-7-4

Configuration of devices under discussion:

- configuration language (according to IEC 61850-6)

Where we are today?

All models will be revised according to the comments received on the CD1.

Missing text needs to be added to refine/define the semantic in a way that it can be interpreted uniquely by different experts all over.

HTML files soon available for easier browsing the information models (mandatory, and mandataory and optional) – education tool.

Wind power plant information exchange

Various (communication) topologies

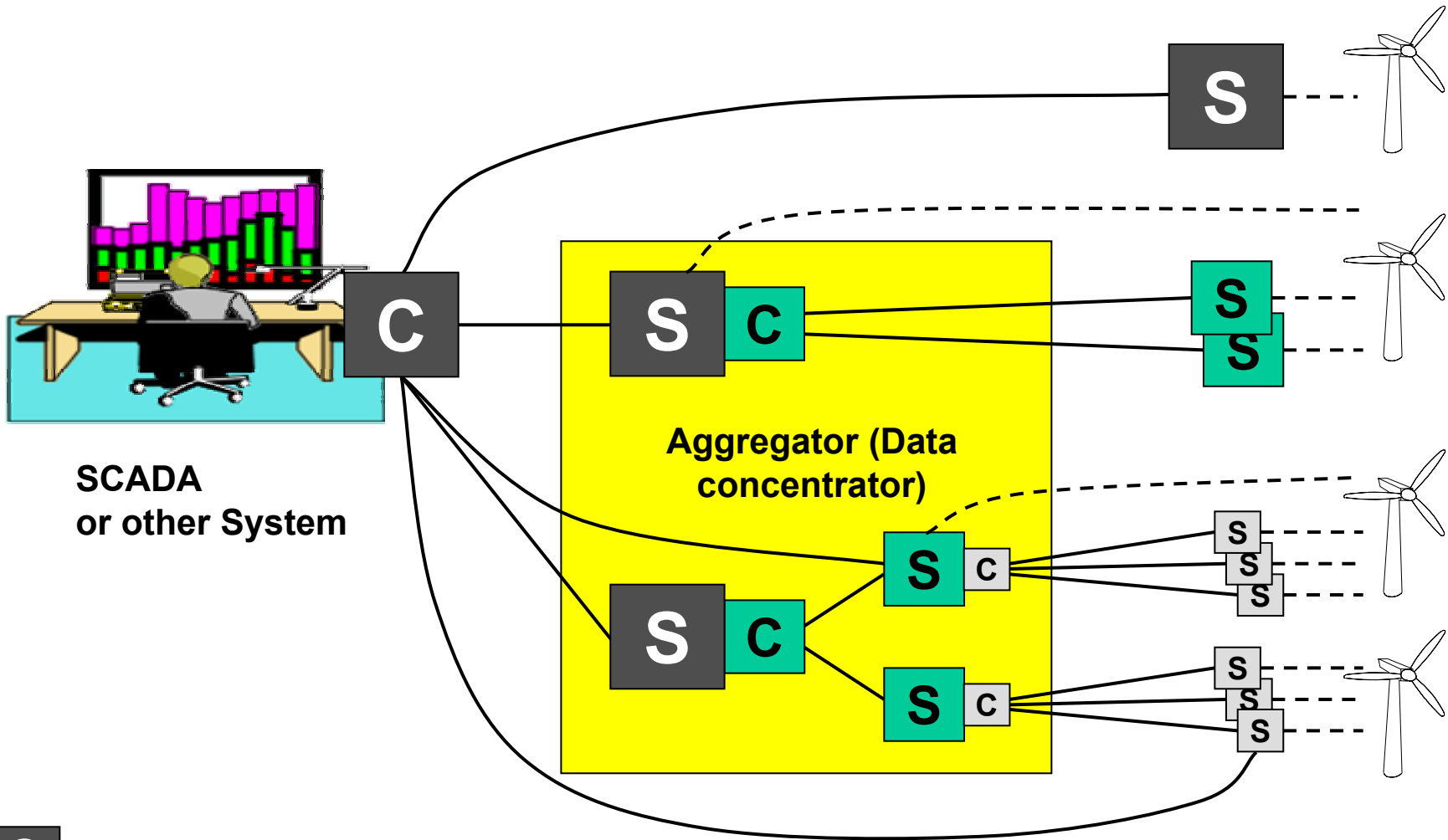

S very comprehensive 61400-25 information model / exchange; Client/Server

S more comprehensive information model / exchange

S Simple information model / exchange

———— IEC 61400-25

- - - - non IEC 61400-25

IEC 61400-25

allows any topology

Scalability

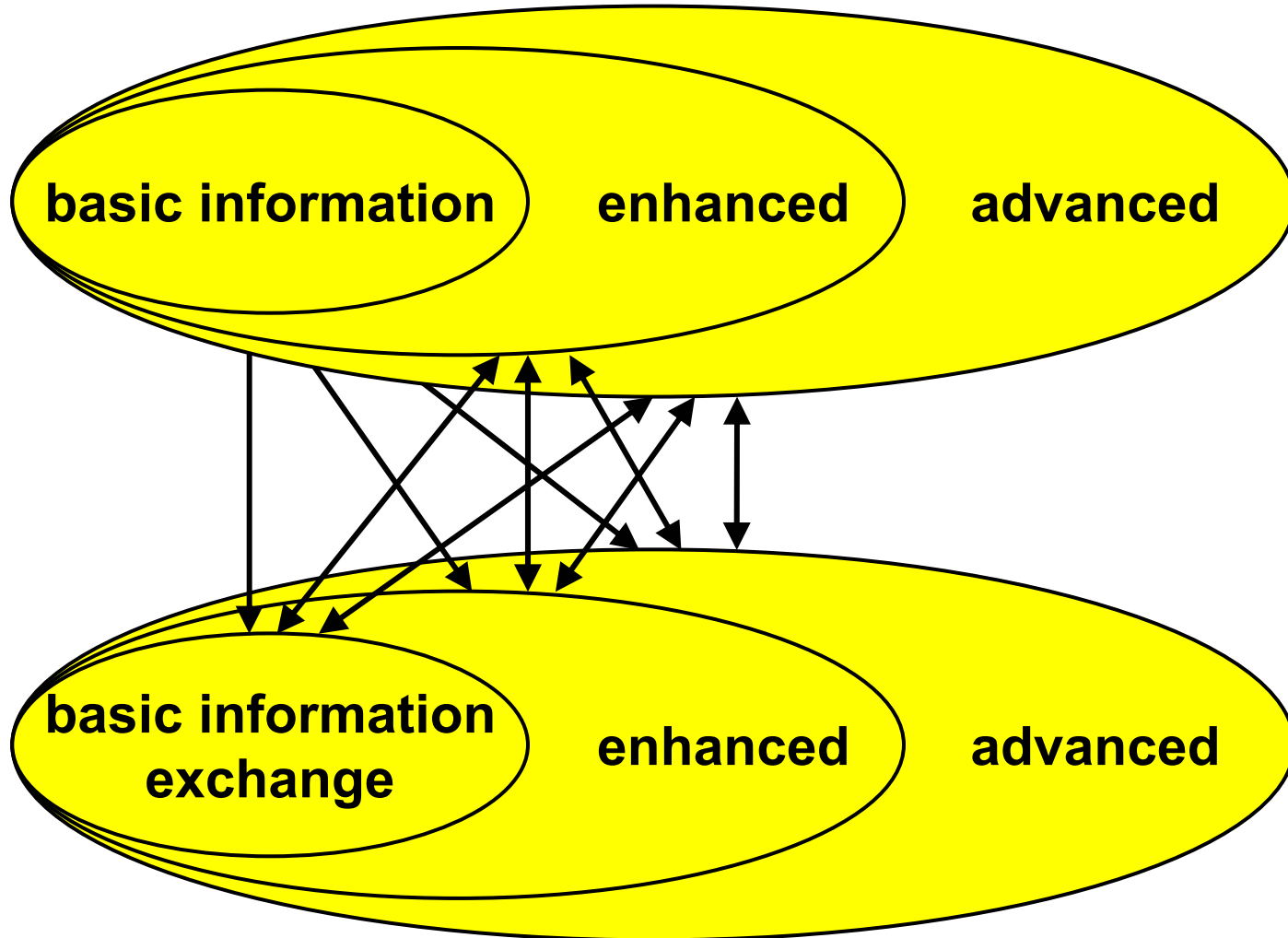

Information exchange

Get information (polling)

Report realtime information

Reporting
(spontaneous, SoE)

SoE = sequence of events

on change,
on update,
cyclically,
...

Retrieve logged information

Logging
(request, SoE)

on change,
on update,
cyclically,
...

Set/Get
configuration/description

Information model

(of an analogue value defined by common data class AMV)



instMag

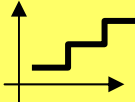

mag

average

rms

maxVal

minVal

...

hourly max [25]

daily max [32]

...

hourly min [25]

config./descr.

...

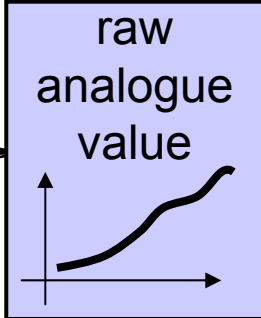

raw
analogue
value



Information exchange

Get information (polling)

Report realtime information

Reporting
(spontaneous, SoE)

SoE = sequence of events

on change,
on update,
cyclically,
...

Retrieve logged information

Logging
(request, SoE)

on change,
on update,
cyclically,
...

Set/Get
configuration/description

Information model

(of an analogue value defined by common data class AMV)



instMag

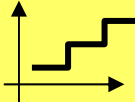

mag

average

rms

maxVal

minVal

...

hourly max [25]

daily max [32]

...

hourly min [25]

config./descr.

...

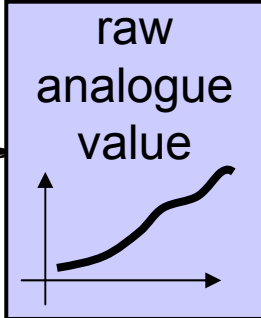

Scalability

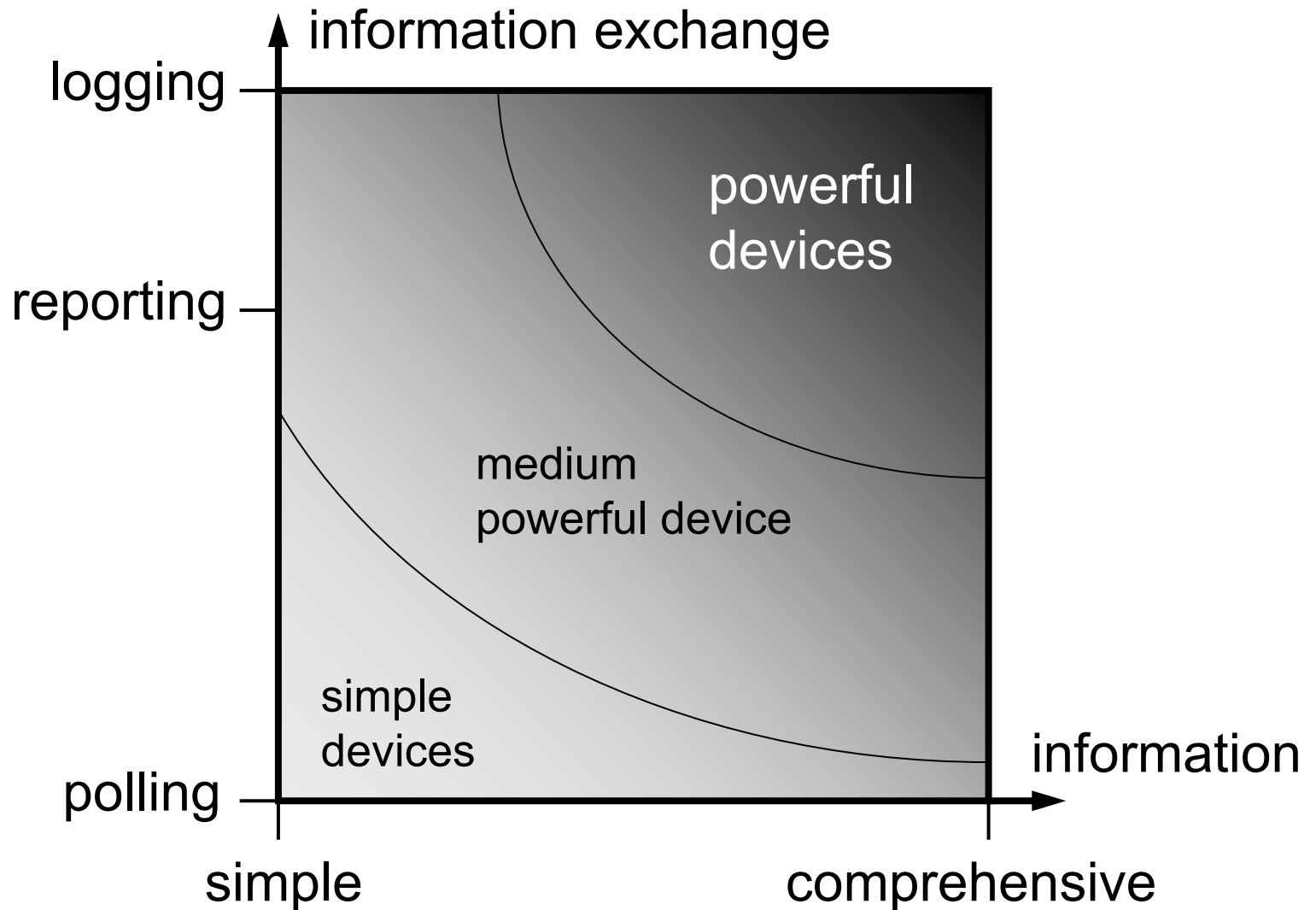

Wind power plant information exchange

Information Exchange Models

Operational communication	Authorisation	Authentication and restriction of access to operational and management functions
	Control	Control of operational devices
	Monitoring	on demand (current or archived), periodic or spontaneous by IED
Management communication	User/access mgmt.	Setting up users, access rights and monitoring access.
	Timesyncr.	Synchronization of device clocks

192.66.76.22

Device model

Server

Logical Device

Data on demand

nameplate, health

MyLD

TotEgyAt

Logical Node

WTUR

Control

Data on demand

Data on demand

Data

reference

diagnostics

reference

values on change, event, periodic

Report Control Block (monitoring and processed information)

Data Set

Query by ime

Log Control Block

Log Control Block

Log

Data Values

Authorisation

Setup

Time Synchronisation

File Transfer

Authorisation model (conceptual)

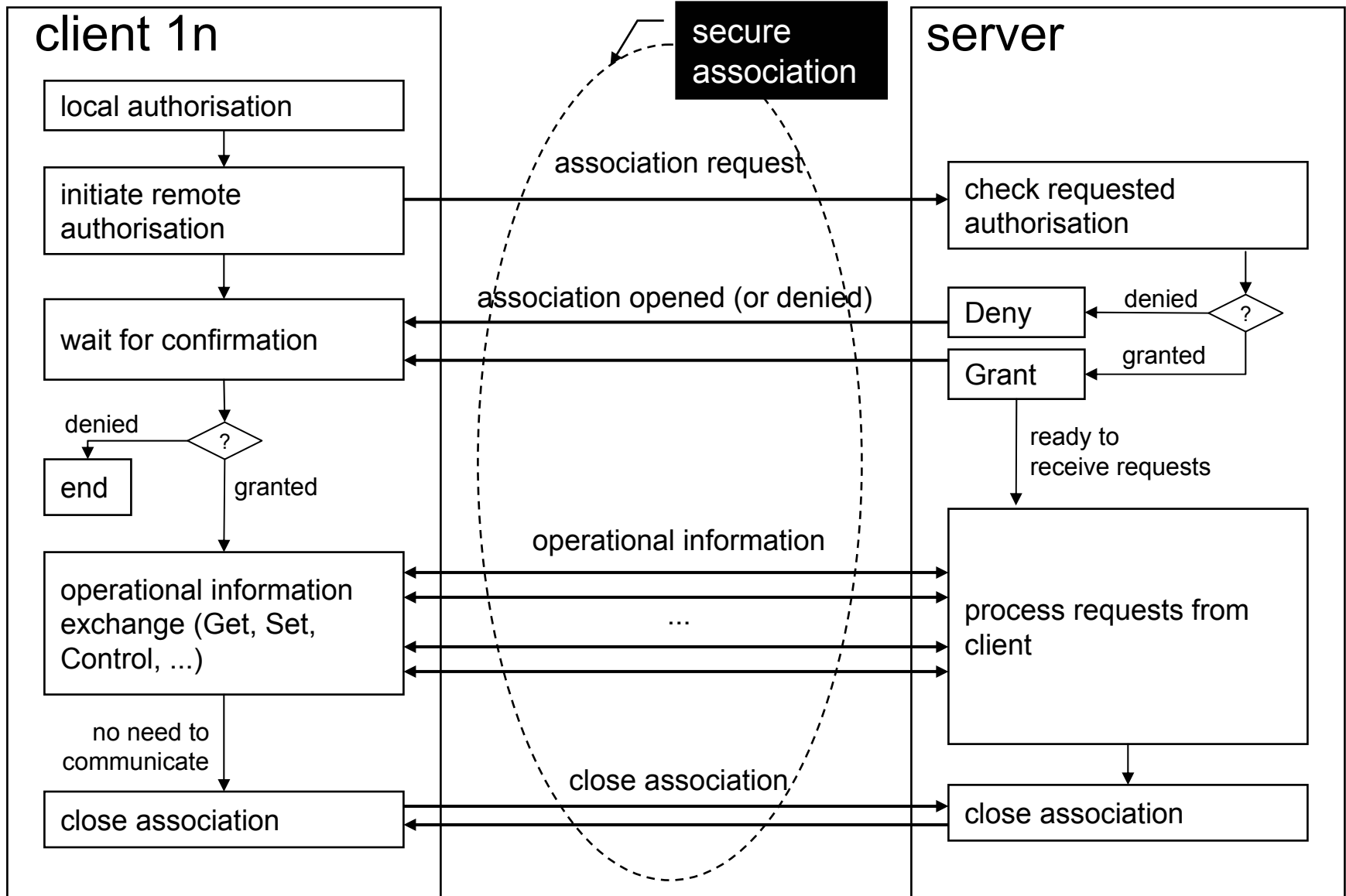

Control model (conceptual)

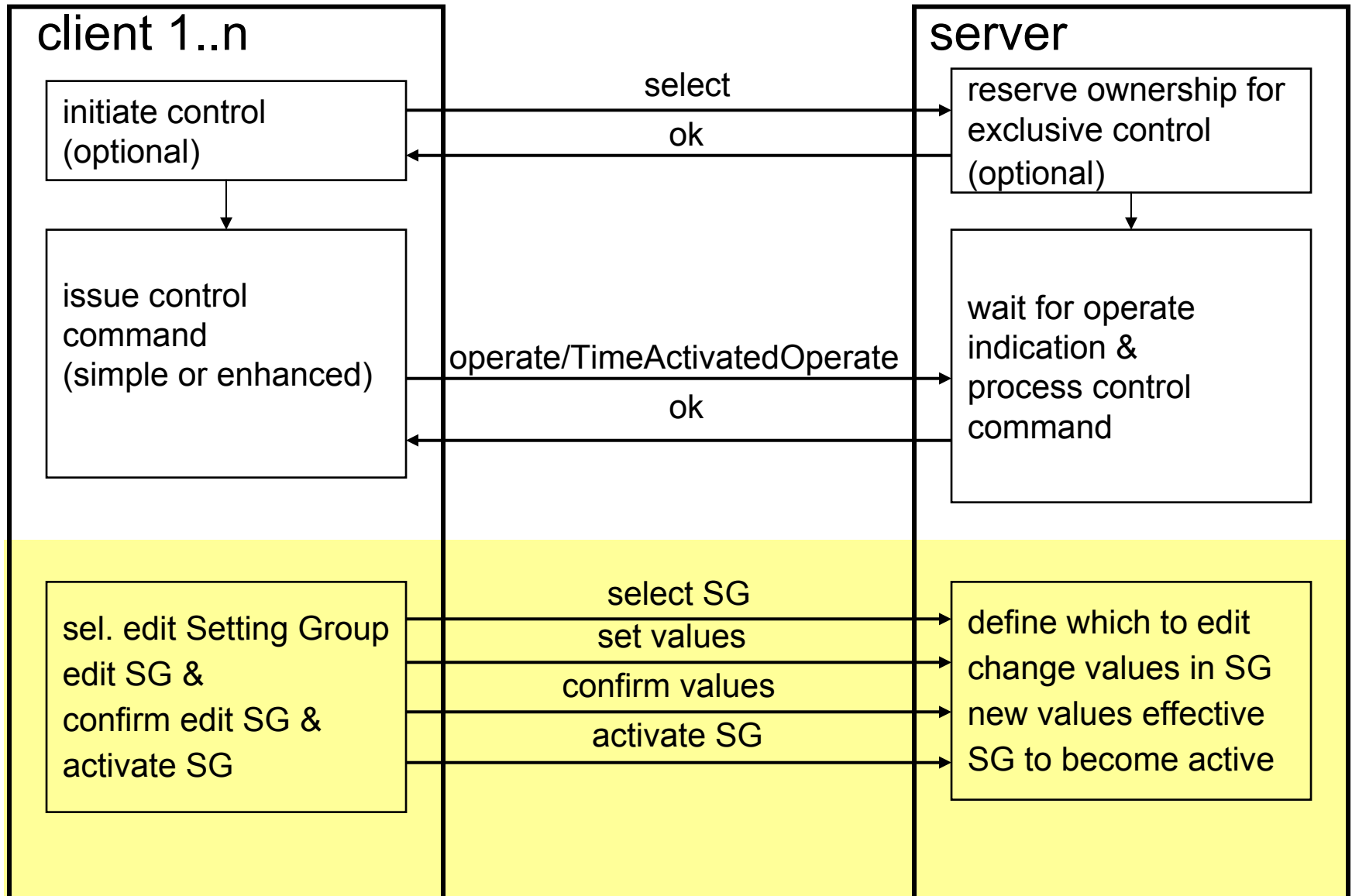

Monitoring model (conceptual)

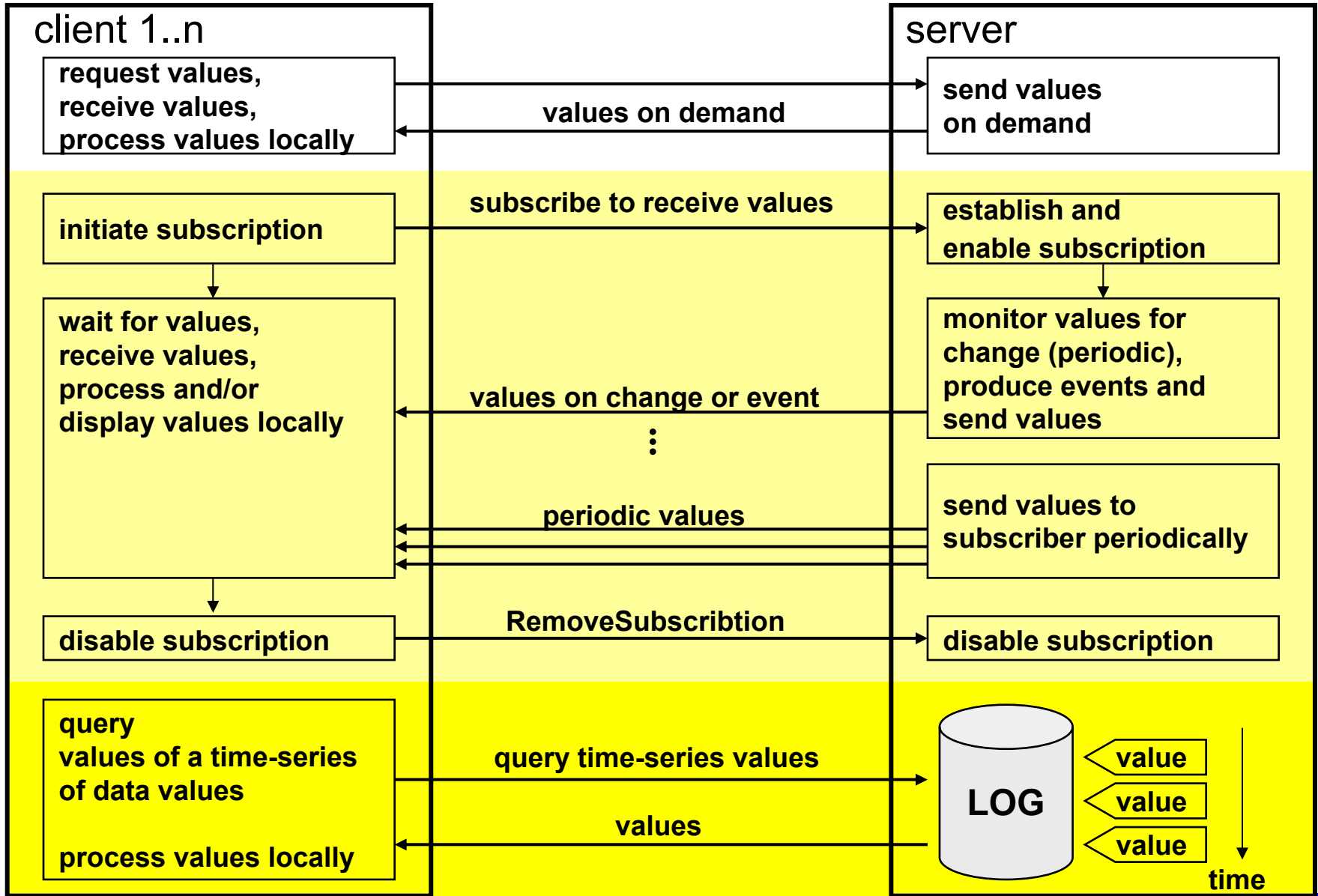

Comparison of the monitoring methods

retrieval method	time-critical information exchange	can lose changes (of sequence)	multiple clients to receive information	last change of data stored by	typical client but not exclusive
Data on demand	NO	YES	YES	-	Browser
Unbuffered Reporting	YES	YES	YES*	-	Real-time GUI
Buffered Reporting	YES	NO	YES*	Server	Data concentrator
Log	NO	NO	YES	Client	Plant operation, engineering stations
Subscription	YES	YES/NO	YES*	Server	Real-time GUI

* with multiple instances of control blocks, one per client

Buffered report control block – conceptual

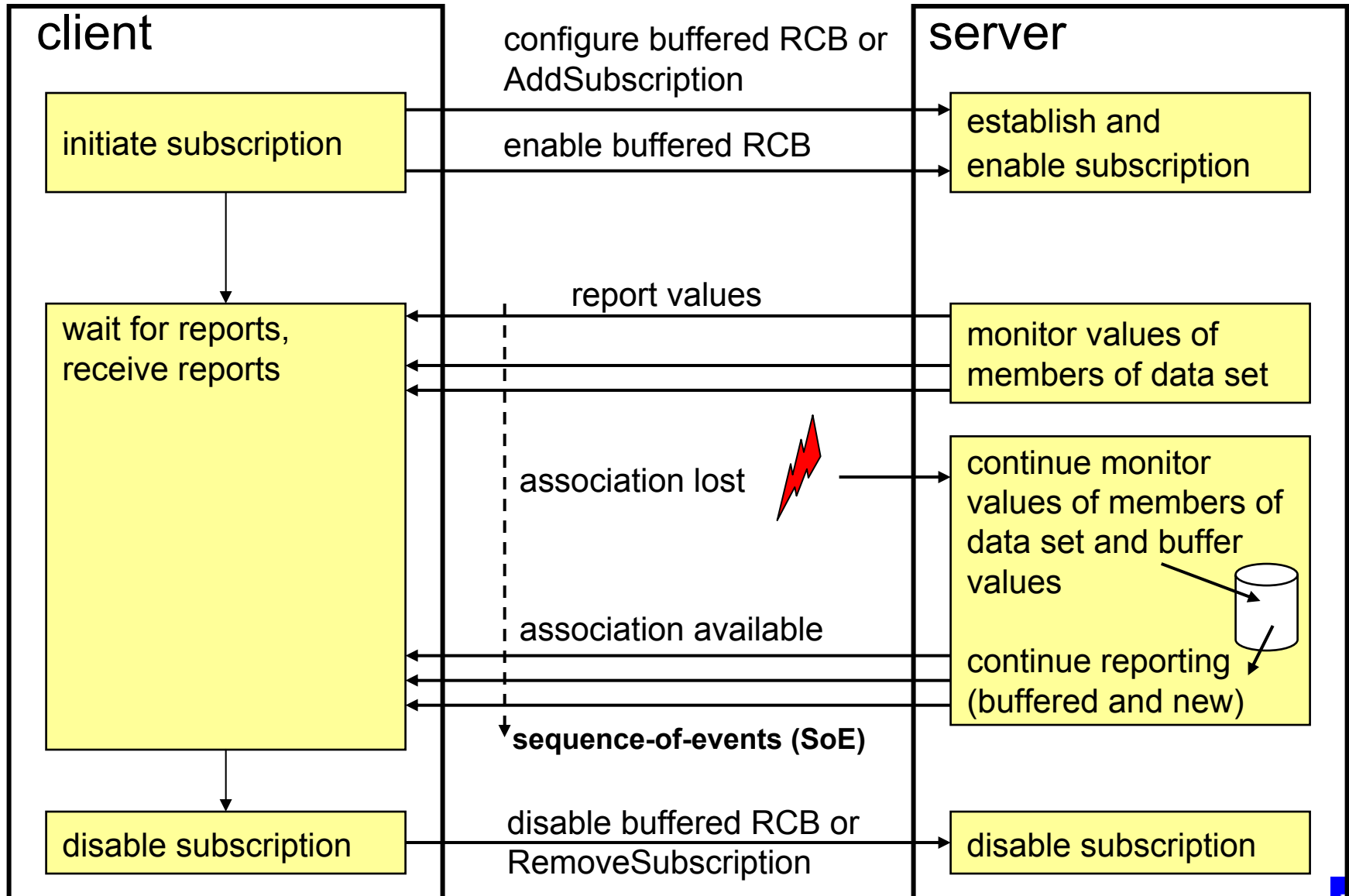

Log control block – conceptual

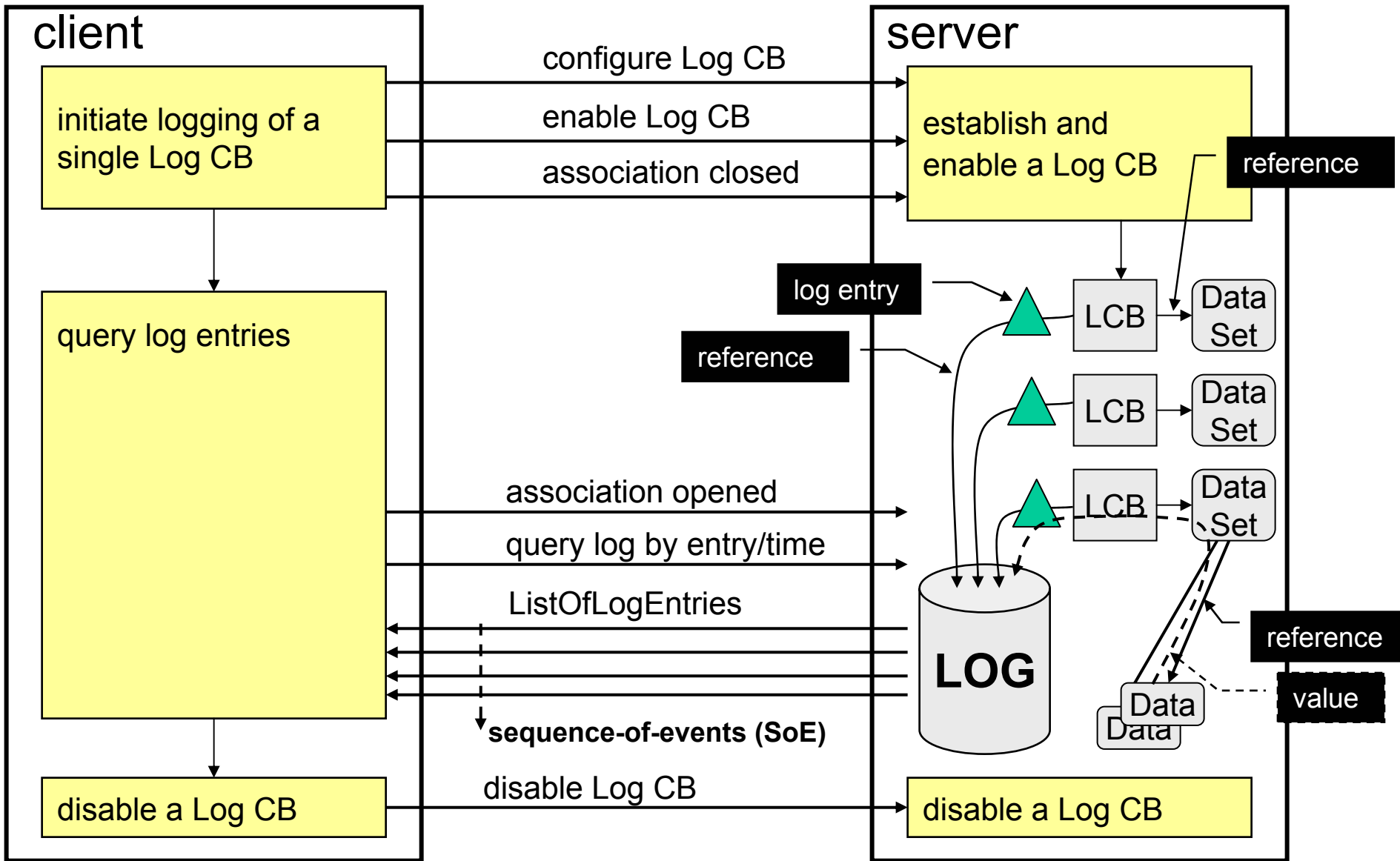

Mapping of Information Models to Data Sets for reporting (conceptual)

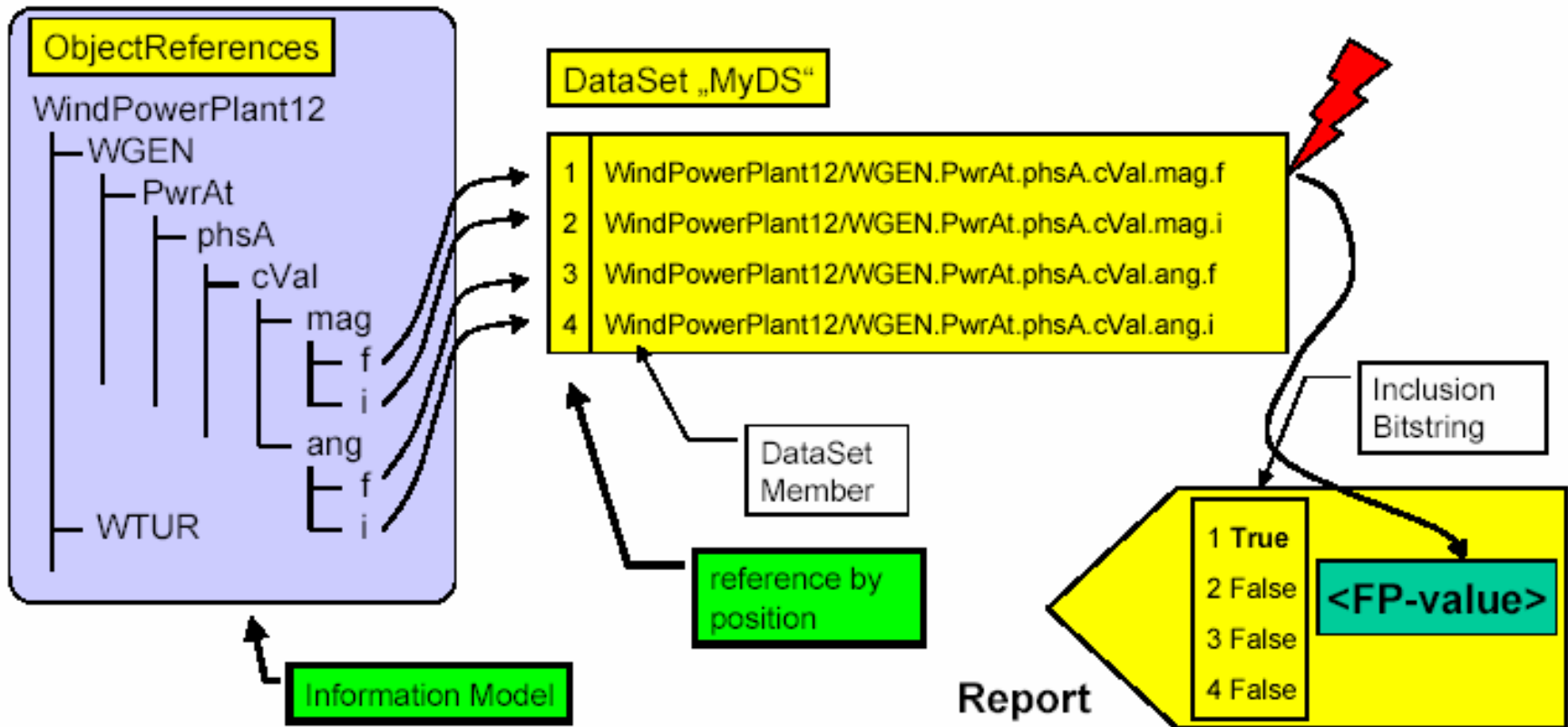

Logging basics (conceptual)

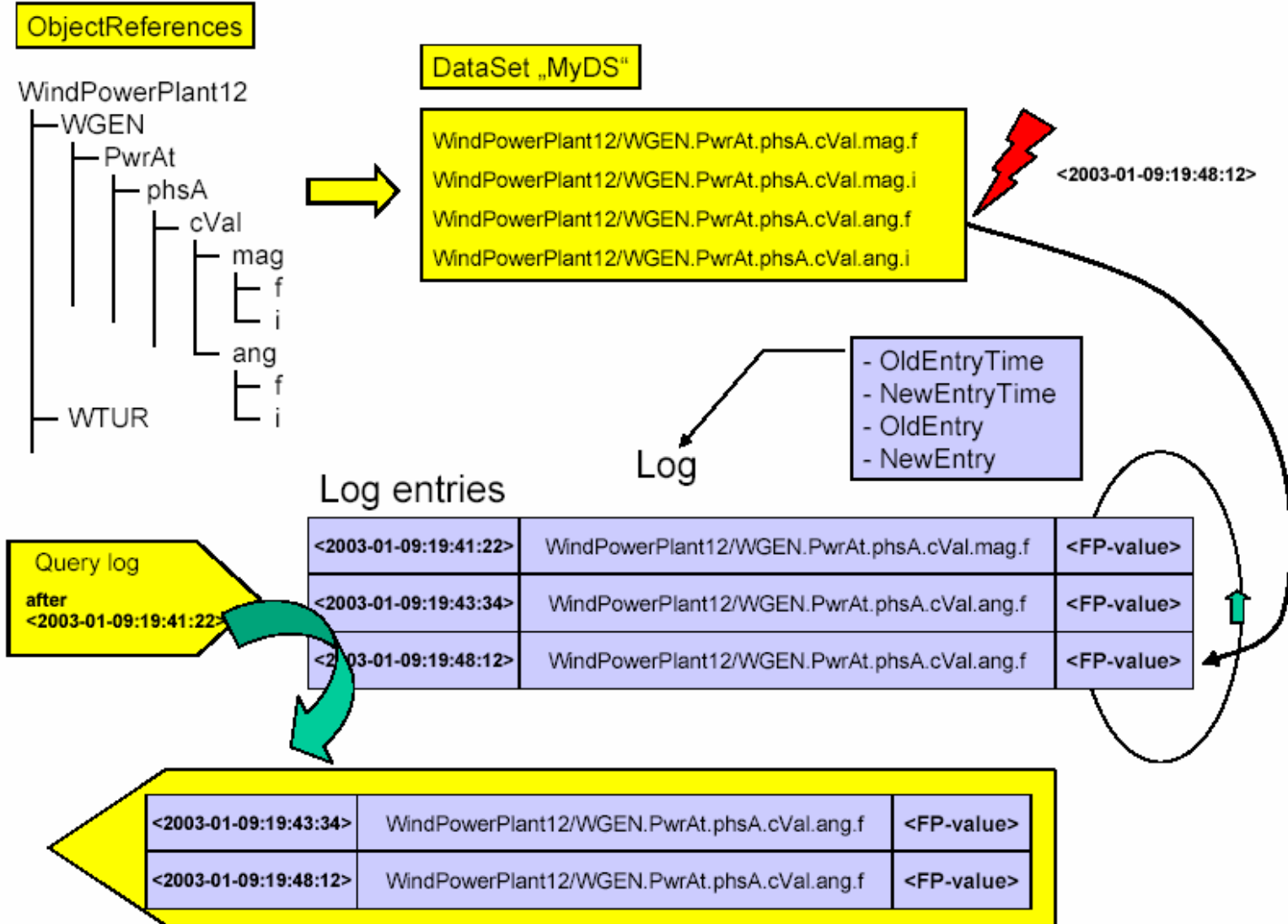

Query log response

Wind power plant
information and
information exchange
mapped to
Protocols/Services

IEC 61400-25 Mappings

Interims NOTE for CD review

Due to the market relevance of the four protocol stacks

- IEC 61850-8-1,
- IEC 60870-5-101/104,
- OPC XML-DA / Webservices, and
- DNP3

the Project Team 25 of IEC TC 88 has agreed to incorporate all four into the first Committee Draft: The National Committees of TC 88 decide on the final set of mappings to be included into the standard IEC 61400-25.

IEC 61850 (61400-25) Mappings

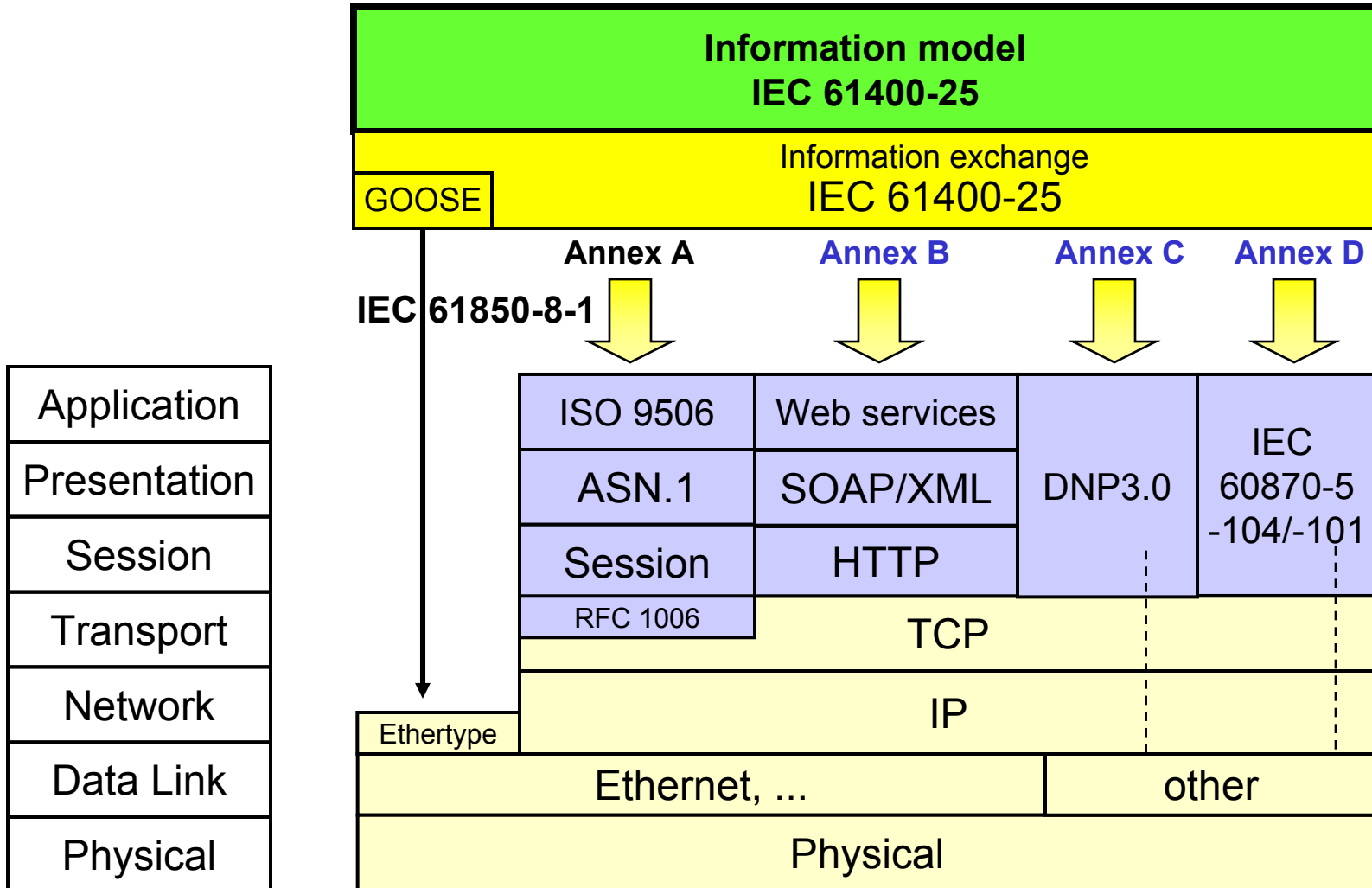

IEC 61400-25 Mappings

Mapping to	Specification could be found in	Main characteristics
ISO 9506 (MMS)	IEC 61850-8-1 (Annex A)	<ul style="list-style-type: none"> – maps all services to binary encoded messages (highly efficient encoding) – maps spontaneous reports (SoE) – maps logging (offline collection and later log query)
IEC 60870-5-101/104	Annex B *)	<ul style="list-style-type: none"> – maps process data value exchange (mainly signals) and provides file transfer of logs
web services	Annex C OPC XML-DA	<ul style="list-style-type: none"> – maps a subset of services (for the exchange of process data values) to ASCII encoded messages defined in OPC XML-DA
	Annex C enhanced web services	<ul style="list-style-type: none"> – maps additional services to SOAP/ASCII encoded messages – maps spontaneous reports (SoE) – maps logging (offline collection and later log query)
DNP3	Annex D *)	<ul style="list-style-type: none"> – maps process data value exchange (signals)

*) The mapping to IEC 61870-5-101/104 or DNP3 respectively requires one of the other mapping for retrieving the wind power plant information model

61400-25 Mapping 60870-5-104



Naturen
i arbeid



Statkraft

Hovedprinsipper:

- Ring-struktur -> Redundans
- Lokale ringer , RWAN
- Nasjonal ring, NWAN

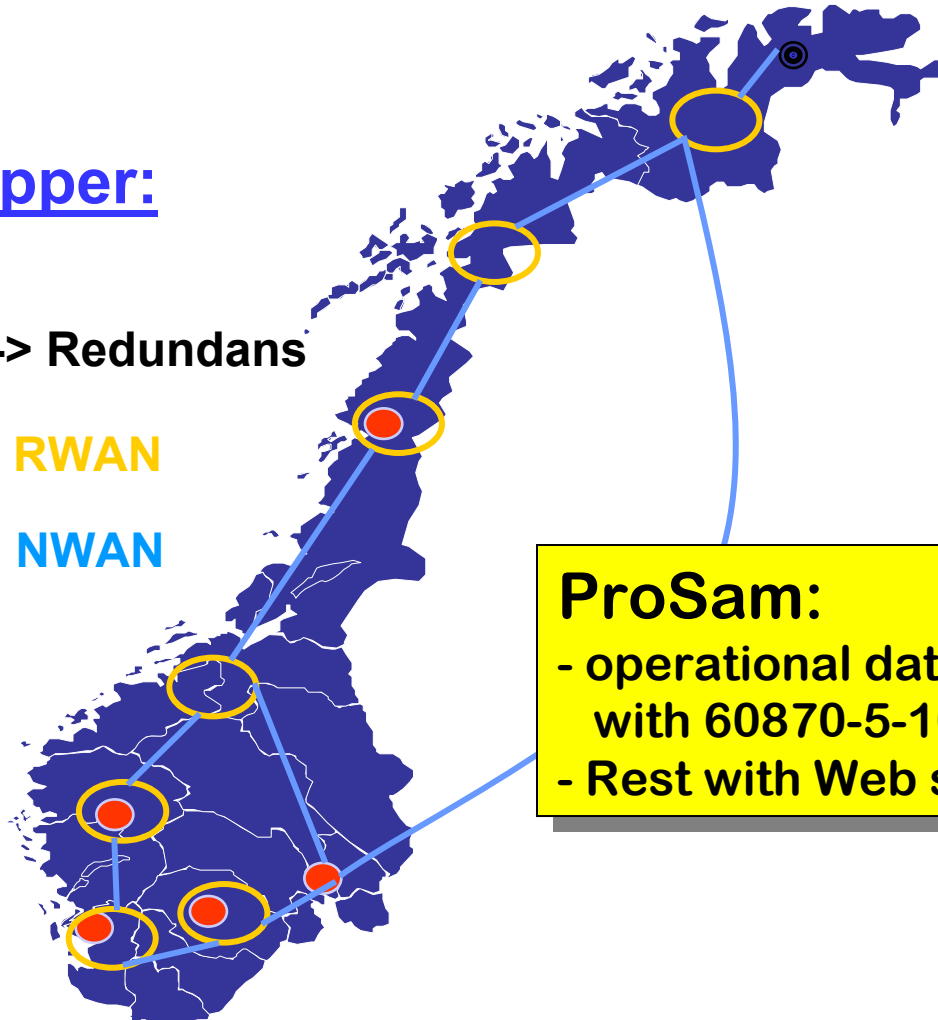

ProSam:

- operational data
with 60870-5-104
- Rest with Web services

by Harald Hilde, Statkraft, Oslo

IEC 61850 (61400-25) Mappings

61850: Samples → Ethertype

61850: GOOSE → Ethertype

61850: Client-Server → ISO 9506 (MMS)

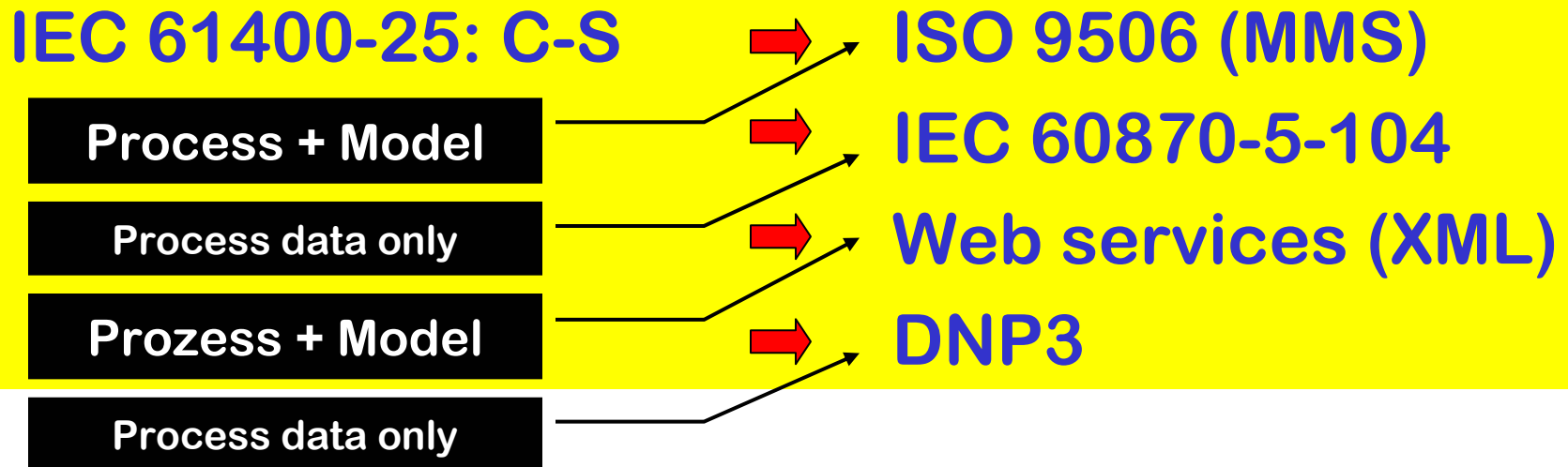

61400-25 Mappings

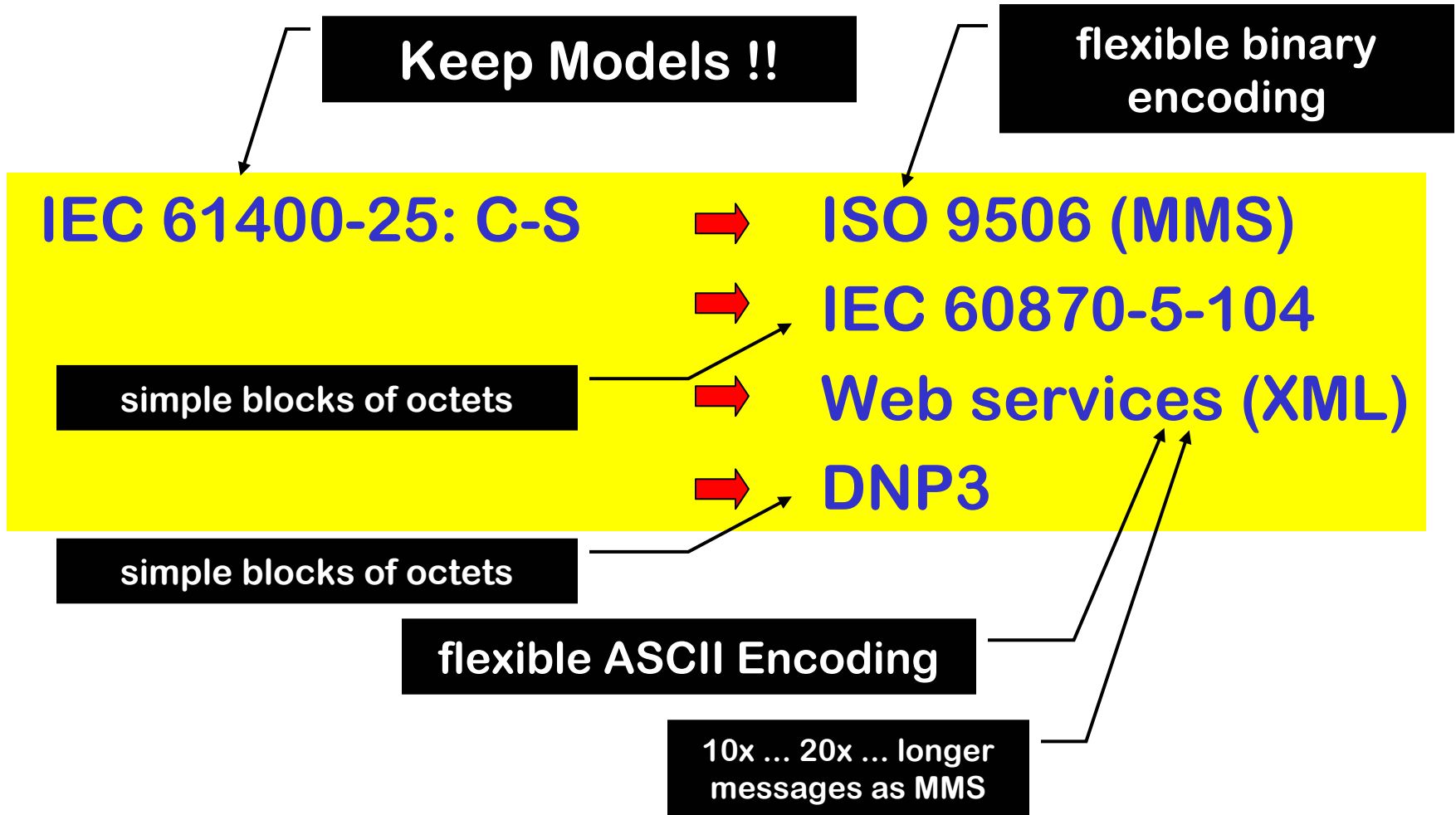

Complete Mapping

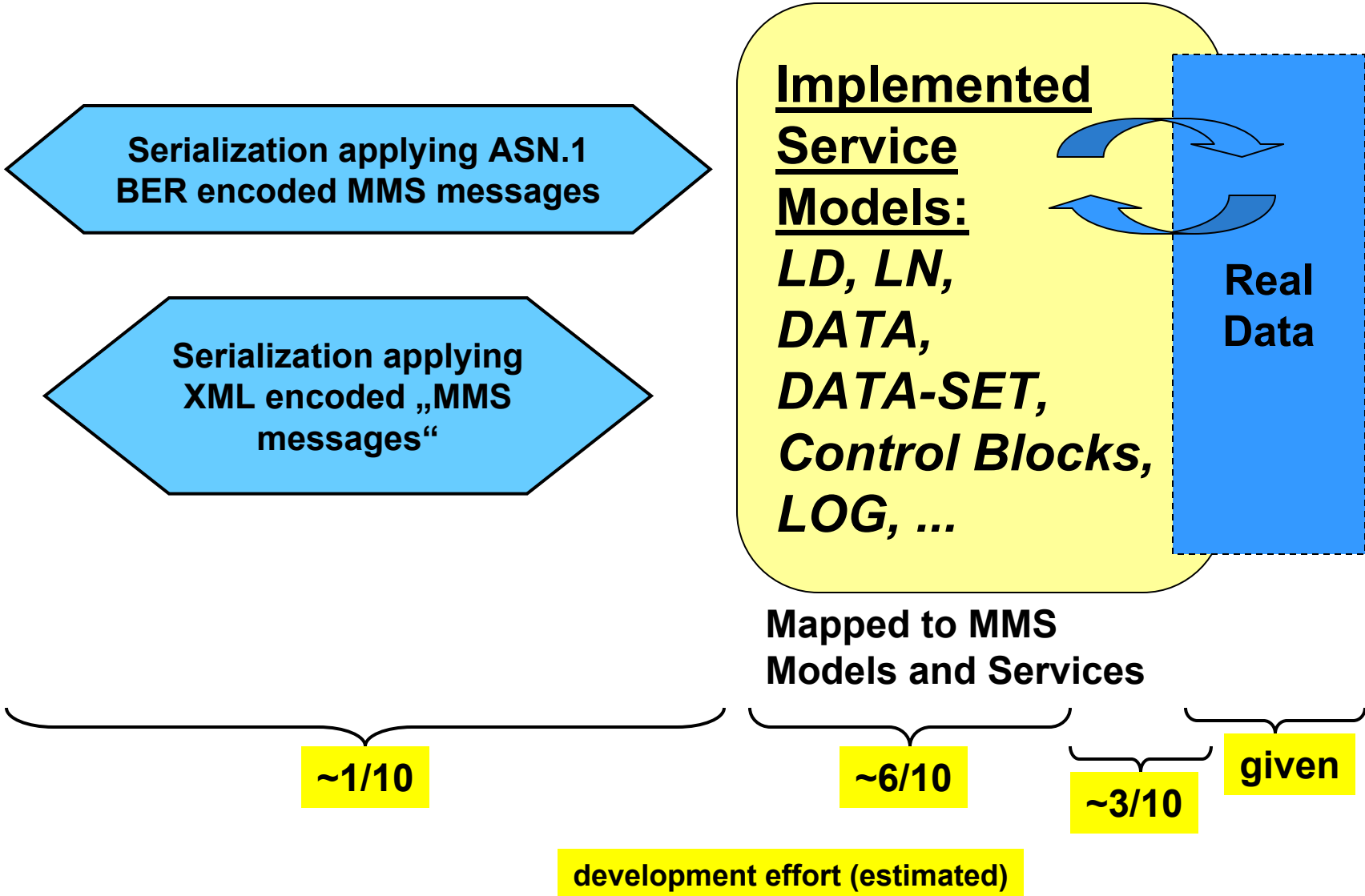

http://192.168.10.06/Sigwards/WEnv\$MX.xml - Microsoft Internet Explorer

Adresse http://192.168.10.06/Sigwards/WEnv\$MX.xml

```

- <MX>
- <WindSpd>
  <mVali mmstype="integer[16]">2226</mVali>
  <q mmstype="bitString[16]">[00000010000000001]</q>
  <t mmstype="binaryTime
    [6]">09/08/2001_16:49:43.721</t>
</WindSpd>
- <WindSpd2>
  <mVali mmstype="integer[16]">2226</mVali>
  <q mmstype="bitString[16]">[00000010000000001]</q>
  <t mmstype="binaryTime
    [6]">09/08/2001_16:49:43.721</t>
</WindSpd2>
- <OutdrTemp>
  <mVali mmstype="integer[16]">2226</mVali>
  <q mmstype="bitString[16]">[00000010000000001]</q>
  <t mmstype="binaryTime
    [6]">09/08/2001_16:49:43.721</t>
</OutdrTemp>
- <AirPres>
  <mVali mmstype="integer[16]">2226</mVali>
  <q mmstype="bitString[16]">[00000010000000001]</q>
  <t mmstype="binaryTime
    [6]">09/08/2001_16:49:43.721</t>
</AirPres>
</MX>

```

XML coded messages (structured text)

37 octet for tags
4 octets for integer value

All values of MX of LN „WEnv“

Complete Mapping with different AL/stacks/encodings

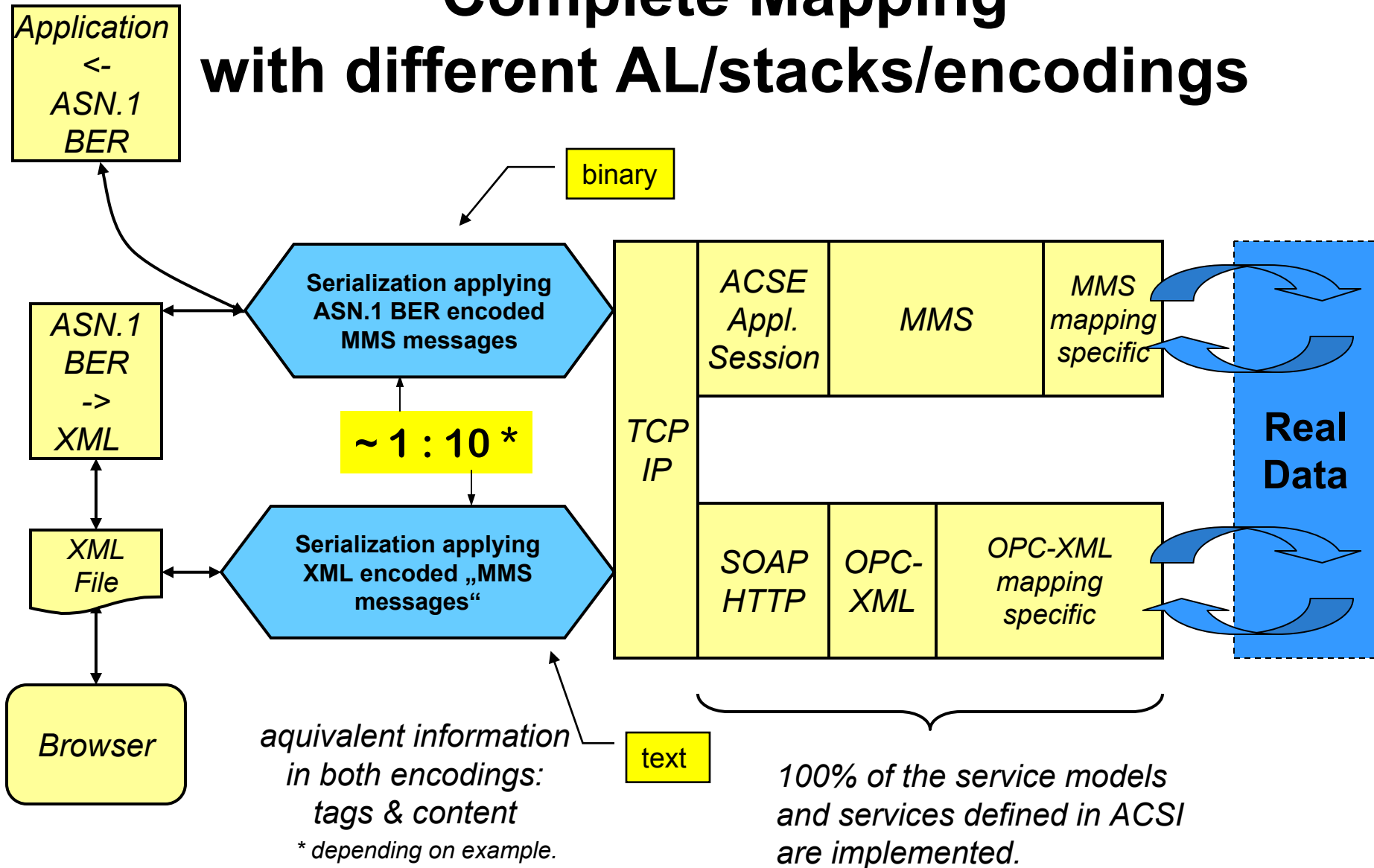

Appendix

Reuse of basic models, services, ...

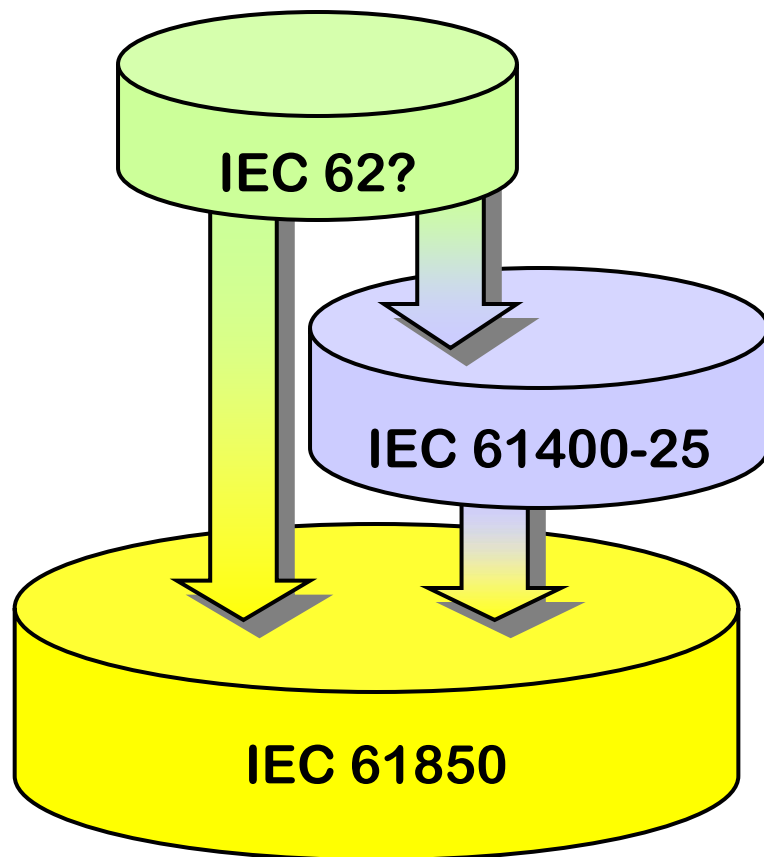

Hydro, Solar,
Fuel Cell, ...

Wind Power
2003 - ...

Substations (HV, MV),
SCADA, 1995 - 2003
Power Quality, 200x

Models of 61850 (61400-25)

90 (10+) Standard LN Models (PDIS, XCBR, ...)

500 (200+) Standard Data (Pos, ...)

OPC: Item

OPC: Properties

100 (100+) Standard Data Attributes (stVal, q, ...)

30 (10+) Standard Common Data Classes

10 (10) Standard Comm.-Service Models

MV, WYE, ...

Excerpt:

<http://www.nettedautomation.com/qanda/iec61850/information-service.html#>

„Layer model“ of IEC 61850 (61400-25)

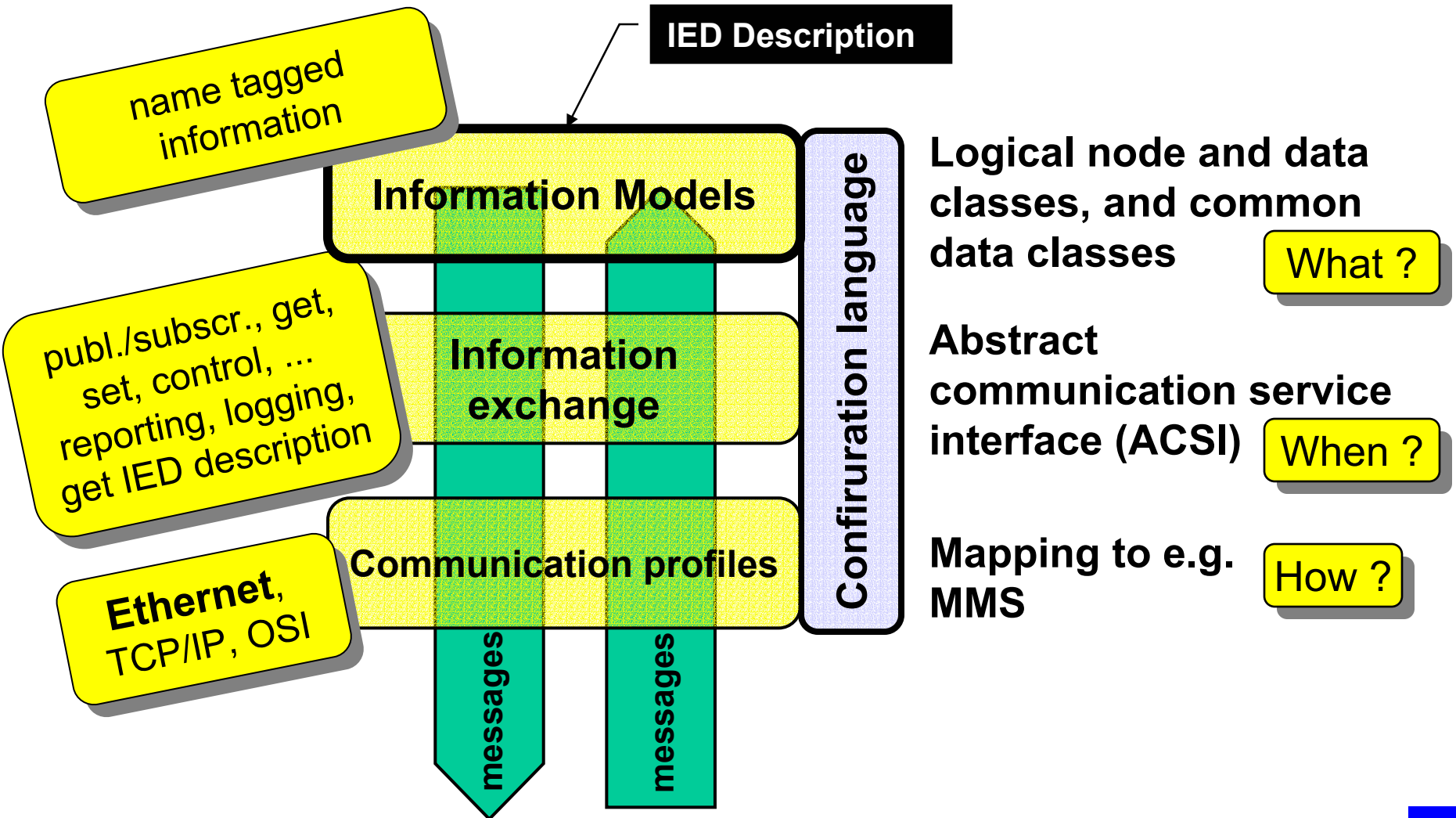

Related Projects

- **IEC 61850, Communication networks and systems in substations (14 parts)**
- **IEC 61850 Addendum for Power Quality Monitoring**
- **DER/ADA (Distributed energy resources / advanced distribution automation) – US-Projekt (IEEE, IEC NP)**
- **IEC 61970-301, Energy Management System API - Common Information Model (CIM)**

New Projects (under ballot)

- **57/660/NP: Communications Systems for Distributed Energy Resources (DER) – extensions of IEC 61850; ballot closes 2003-12-05**
- **57/661/NP: Hydroelectric power plants – communication for monitoring and control – extensions of IEC 61850; ballot closes 2003-12-05**

Proposal of IEC TC 57 (Montreal, Oct 2003) → SB1/SMB: Coordination of information objects for electrical power systems within IEC based on IEC 61850 ... to define and keep the overall data models consistent – preferably under one publication number (IEC 61850-x-y).

New Projects (under ballot)

- **IEC 57/675/NP - Data and Communication Security - Security for IEC 60870-5 and Derivatives; ballot closes 2004-01-16**
- **IEC 57/676/NP - Data and Communication Security - Management Information Base (MIB) Requirements for End-to-End Network Management; ballot closes 2004-01-16**
- **IEC 57/677/NP - Data and Communication Security - Security for IEC 61850 Profiles; ballot closes 2004-01-16**
- **IEC 57/678/NP - Data and Communication Security - Communication Network and System Security - Profiles Including MMS; ballot 2004-01-16**
- **IEC 57/679/NP - Data and Communication Security - Communication Network and System Security - Profiles Including TCP/IP; ballot closes 2004-01-16**

MAYA – Distributed Monitoring for Power Systems

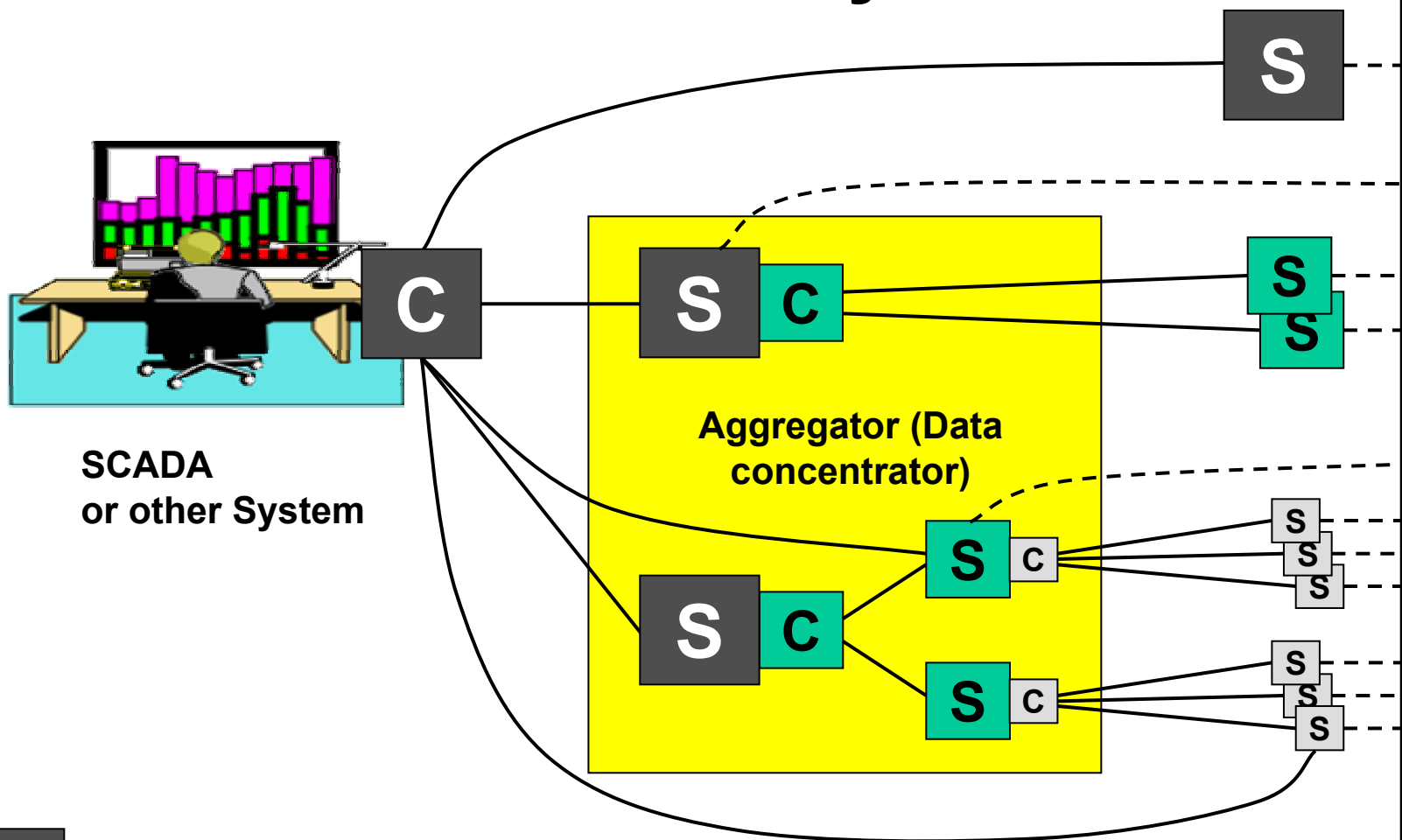

Any intelligent power system device (wind power, substation, RTU, DER, hydro, power quality, ...)

- S very comprehensive IEC 61400-25/61850 information model / exchange; Client/Server
- S more comprehensive information model / exchange
- S Simple information model / exchange

———— IEC 61400-25/61850

- - - - - non IEC 61400-25/61850



Transshipping from boxes (lists) to sacks (other lists) ...

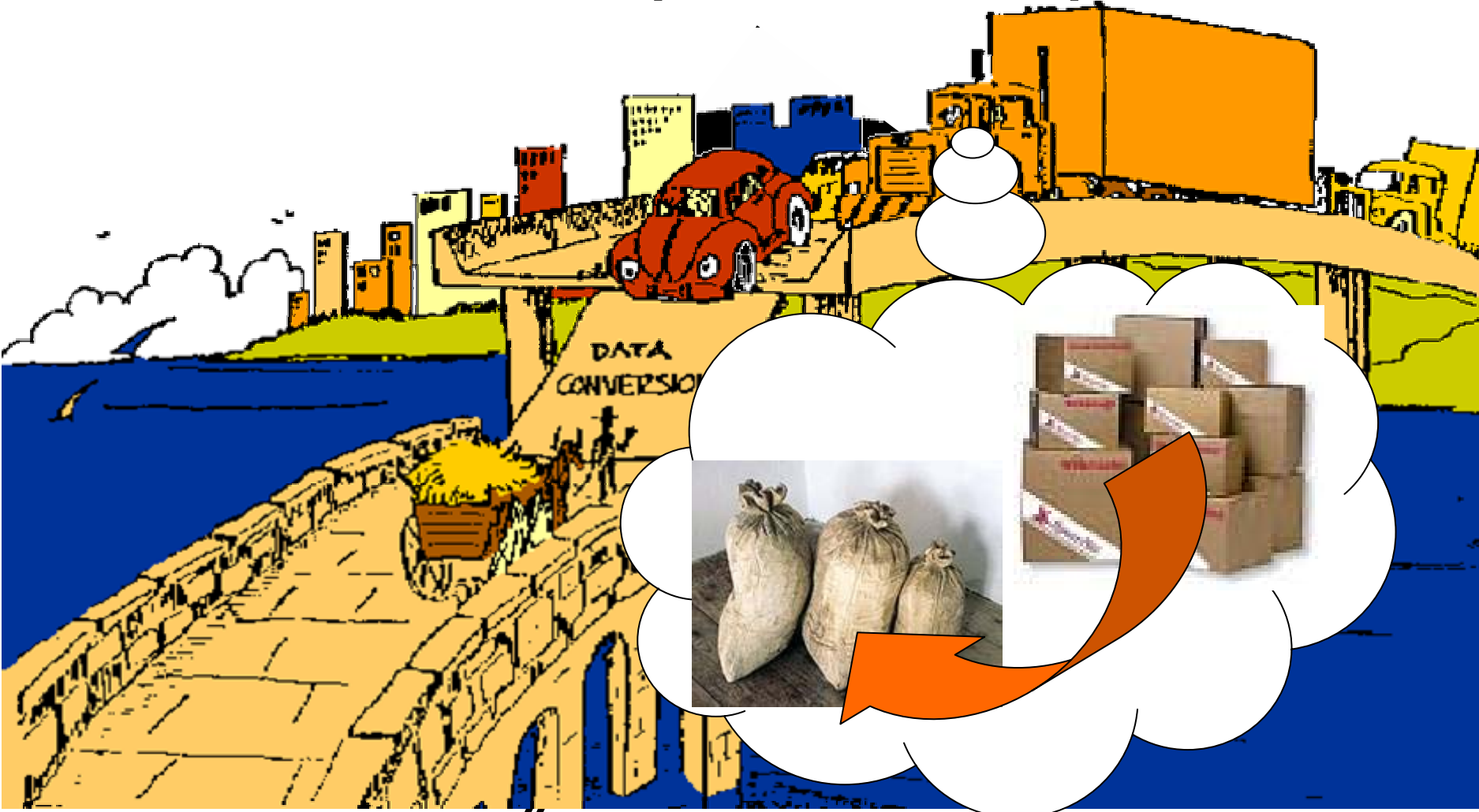

**IEC 61400-25
and IEC 61850
help you !**

Question ?